

TIGER 50

Audacity Models . . . where performance exceeds expectations!

For technical updates, and
additional information visit:

www.audacitymodels.com



CCPM

- *Cyclic*
- *Collective*
- *Pitch*
- *Mixing*

Entire Contents © Copyright 2004



PLEASE READ THIS MANUAL FULLY AND CAREFULLY!

This helicopter model is not a toy and is not suited for children. Contact with the rotating parts of this model helicopter may cause bodily harm and/or death as well as property damage. You, and you alone, are responsible for the safe operation of this remote controlled model helicopter. Audacity Models assumes no liability for harm or damage that could occur from the assembly and/or use/misuse of this product. This manual does not serve as a final and total instruction in the safe and proper assembly and operation of remote controlled models.



WARNING

You are about to embark on a wonderful adventure into the world of remote controlled (R/C) models. However, this helicopter model is not a toy and is not suited for children. A properly assembled and operated remote controlled model helicopter can bring many hours of enjoyment and pleasure, but even if properly assembled and operated, the nature of an R/C system means the radio-link between transmitter and receiver may fail, in which case even competent operators are no longer in control. In addition, due to operator neglect or accident, worn or damaged parts may fail causing lack of control. Contact with the rotating parts of this R/C model helicopter may cause bodily harm and/or death as well as property damage. In addition, the overall mass of the model in motion means contact with non-rotating parts may cause bodily harm and/or death as well as property damage.

You, and you alone, are responsible for the safe operation of this R/C model helicopter and Audacity Models assumes no liability for harm or damage that could occur from the assembly and/or use/misuse of this product. This manual does not serve as a final and total instruction in the safe and proper assembly and operation of remote controlled model helicopters. Always have personal supervision by a modeler experienced in the safe and proper handling of R/C model helicopters.

INDEX



Carefully follow the 8 major assembly steps in the correct sequence.

Assembly Steps	Page	Assembly Steps	Page
0.0 Preparation For Assembly	1-5	5.2 Tail Output Shaft	18
1.1 Clutch Bell	6	5.3 Tail Pitch Lever	19
1.2 Tail Drive	6	5.4 Tail Rotor Hub	19
1.3 Elevator Link	7	5.5 Tail Rotor Grip	20
1.4 Fuel Tank	7	5.6 Vertical Fin	20
2.1 Servo-Boss	8	5.7 Tail Boom Assembly	21
2.2 Main Frame	9	5.8 Tail Boom Supports	22
2.3 Avionics Platforms	10	5.9 Boom Support Clamp	22
3.1 Landing Gear	11	6.1 Servo Installation	23
3.2 Main Gear & Shaft	12	6.2 Tail Rotor Pushrod	24
3.3 Engine Mount & Fan	13	6.3 T/R Pushrod Guides	24
3.4 Clutch & Extension	13	6.4 Avionics Isolation	25
3.5 Engine & Start Shaft	14	7.1 Linkages (Port)	26
3.6 Hex Adapter / Muffler	14	7.2 Linkages (Starboard)	27
4.1 Swashplate / Washout	15	8.1 Blade Balance	28
4.2 Head & Flybar Arm	16	8.2 Main Blades	29
4.3 Flybar Installation	16	8.3 Canopy & Windshield	29
4.4 Flybar Paddles	17	9.0 Set-up Tips	30-43
4.5 Rotor Control Rods	17	11.0 Exploded Views & Parts Lists	44-58
5.1 Tail Gear Box & Belt	18	12.0 Accessories	59-61

ITEMS NEED TO COMPLETE

6-channel - or greater
R/C Helicopter System
w/120° CCPM capabilities

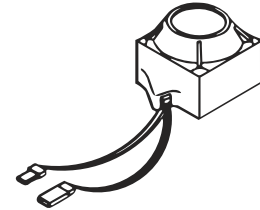
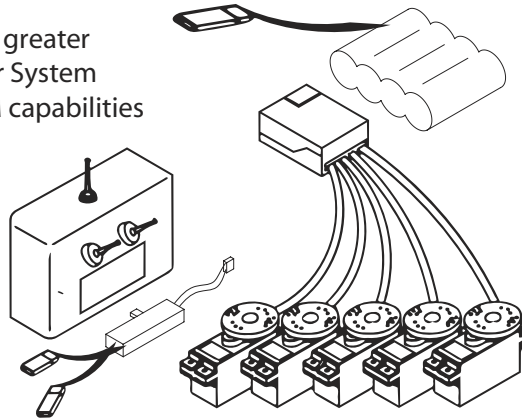

Gyroscope

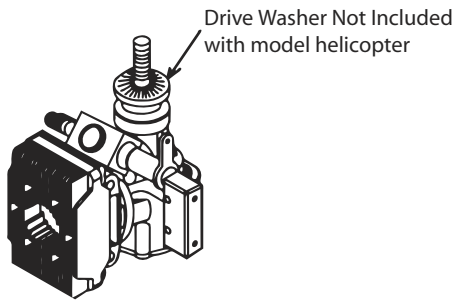

50-class Glo-Fuel Engine

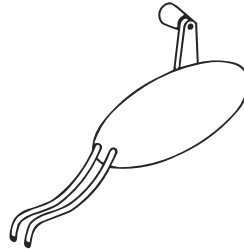

Glo-Fuel Pump

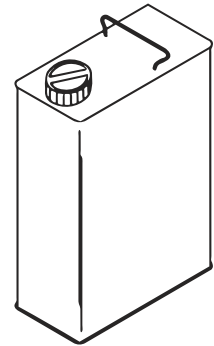

Helicopter Fuel
(15%-30% Nitro)

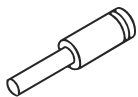

1.2V Ni-Start Battery

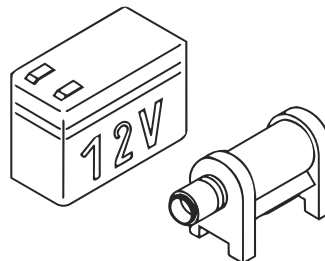

12V Gell-Cell Battery
and Electric Starter

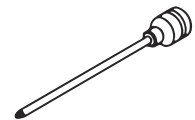

6mm Hex Start Shaft

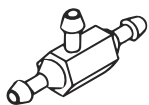

Fuel Filter
(3-way)



12" Fuel Tubing
(1/8" Silicone)

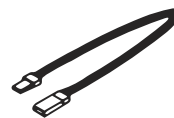

Servo Extensions
(2 each - 4" Long)

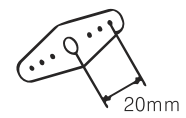

Cyclic/Collective
Servo Control
Horns (x3)

TOOLS NEEDED FOR ASSEMBLY



Phillips Screw Driver



Nut Drivers (4mm/5.5mm/7mm)



Allen Drivers (1.5mm/2mm/2.5mm/3mm)



Drill Bit 1/16"



Auger - or - Reamer

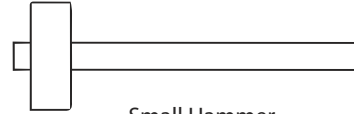

Small Hammer



Wrench (5.5mm/6mm)

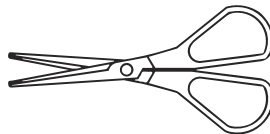

Lexan Scissors

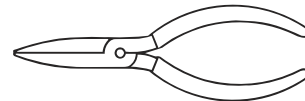

Needle-nose Pliers



Hobby Knife



Ruler (metric) Greater Than 30cm

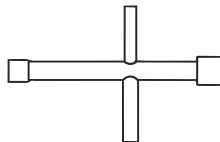

4-way Wrench (8-12mm)

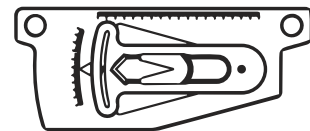

Pitch Gauge

Thread Locker Is Used To Keep Assemblies Tight As Vibration May Cause Them To Loosen



Semi-permanent
BLUE Thread Locker

Due to the vibrations caused by operation, nuts, bolts, and set screws may have a tendency to loosen. Repeated tightening is not the solution, instead, the careful application of thread locker is required. Thread locker works something like a glue. There are various types of thread locker, from permanent types which are usually RED in color, to semi-permanent types which are usually BLUE in color. BLUE thread locker is what is recommended. Thread locker is not needed with nylon-lock nuts, nor where metal screws thread into plastic. Finally, be careful to remove all traces of oil or grease by applying a degreaser or acetone to bolts prior to assembly - clean with a paper towel until all traces are gone.

NOTE: Use care when using thread locker near bearing areas as contamination may ruin the bearing and cause it to seize.

Never use thread locker on metal to plastic

Optional Tools and Accessories:

- Dial Indicator
- Ball Link Pliers
- Piston Locking Tool
- Calipers
- 10mm deep-well thin wall socket
- 2 ea. - 5/16" or 8mm 1/4" drive socket
- 2 ea. - 1/4" drive short extensions and 1/4" handles or drives
- one sheet of thin typing paper

HARDWARE IDENTIFICATION

Various size nuts, bolts, set screws, and washers are used in the **Tiger 50** helicopter. Metric dimensions are given, first specifying the diameter \textcircled{A} of the bolt or screw, then the length \textcircled{B} of the bolt or screw. Washers and nuts are identified by the ID (inner diameter) of the piece. Bearings are identified in order, by ID, (inner diameter), then OD (outer diameter), then W (width). Below are some examples of the types of hardware used.

* **NOTE:** Do not use thread locker when a metal screw goes into plastic as this may damage the plastic and cause failure.

M2x8mm Phillips Head Screw

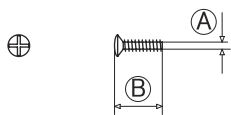

M2x8mm Self-tapping Screw

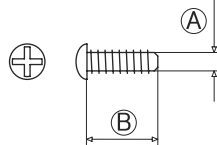

M4x4mm Set Screw

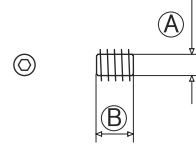

M3x8mm Socket Head Bolt

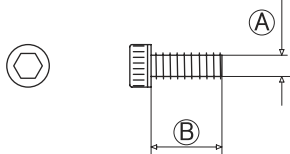

M2mm Hex Nut

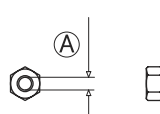

M3mm Nylon Lock Nut

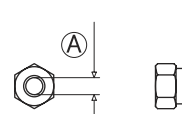

M3mm Lock Washer

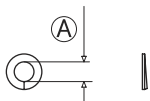

M3mm Flat Washer

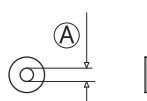

Bearing L-1910ZZ
M10x19x7mm (ID, OD, W)

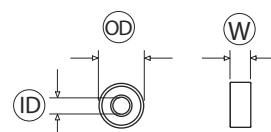

1.1 CLUTCH BELL



* **NOTE:** Thoroughly clean the shaft-threads and the hole-threads of any swarf (tiny metal shavings), before applying thread locker to ensure precise alignment between the pinion gear and clutch bell. Use special care to prevent thread locker from entering the bearing!



Bearing L-1910ZZ
M10x19x7mm

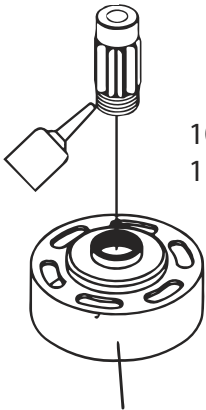

10T Pinion Gear
1 : 8.9 Ratio

Clutch Bell Assembly

Bearing L-1910ZZ

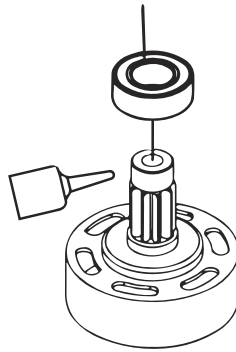

* **NOTE:** Use a rocking side-to-side motion to slip bearing onto shaft.

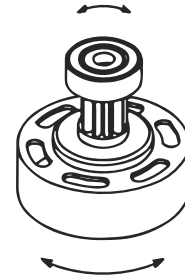

* **NOTE:** Use a rotating motion to twist the the clutch bell assembly simultaneously.

1.2 TAIL DRIVE



M3x6mm Socket Head Bolt (x1)



M3mm Flat Washer (x1)



Bearing R-1960ZZ
M6x19x6mm (x2)

* **NOTE:** Beveled side faces belt-side of pulley.

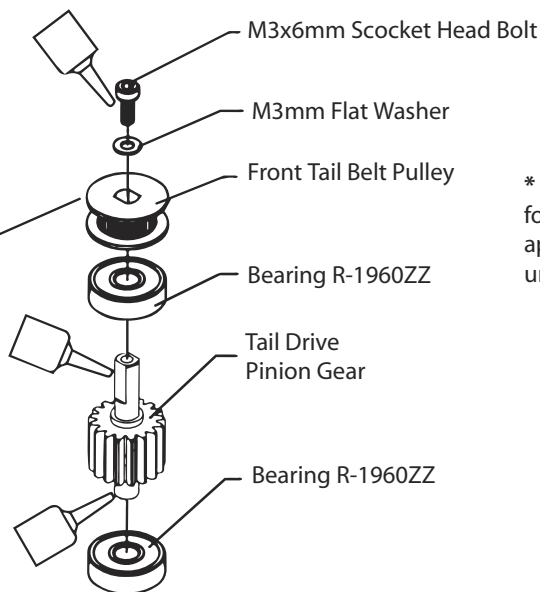

* **NOTE:** It can take several hours for the thread locker to dry after application - do not use assembly until it's completely set.



* **NOTE:** Use special care to prevent thread locker from entering the bearings!

1.3 ELEVATOR LINK

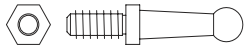

14.5mm Long Ball Arm (x1)

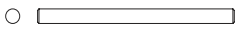

Elevator Arm Pin (x1)



M2x10mm Socket Head Bolt (x2)



M2mm Flat Washer (x2)

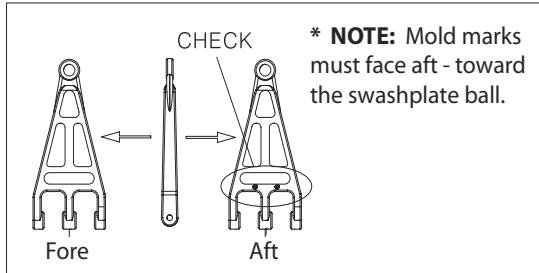

*** NOTE:** Mold marks must face aft - toward the swashplate ball.

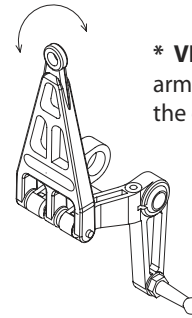

*** VERIFY:** swashplate arm pivots freely on the elevator arm.

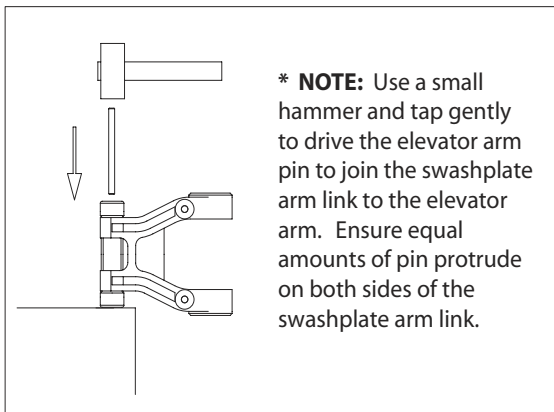

*** NOTE:** Use a small hammer and tap gently to drive the elevator arm pin to join the swashplate arm link to the elevator arm. Ensure equal amounts of pin protrude on both sides of the swashplate arm link.

Swashplate Arm Link

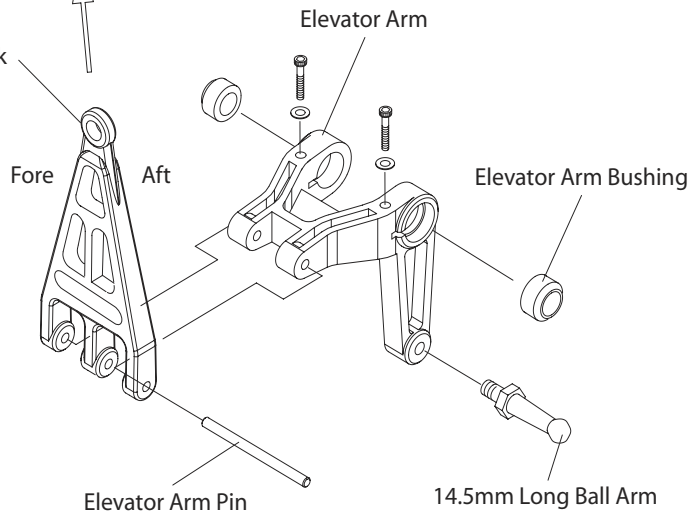

1.4 FUEL TANK

Fuel Feed Line: 1/8" Silicone Fuel Tubing (not included) - Du-Bro Medium (blue) Silicone - No. 197 recommended.

*** PRO TIP:** For high nitro use, replace the included small diameter silicone fuel pickup line with 1/8" ID silicone fuel tubing. **Replace yearly!**

Fuel Tank - 14 oz practical capacity

*** NOTE:** Check fuel tank for swarf before assembling it!

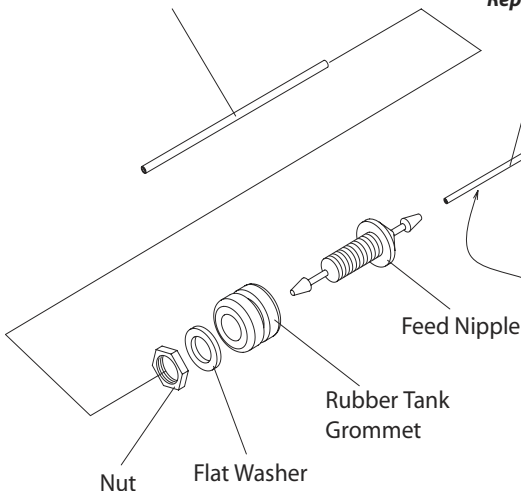

*** PRO TIP:** add a small dab of silicone RTV at the four tank mounting points when you assemble the fuel tank into the main frames.

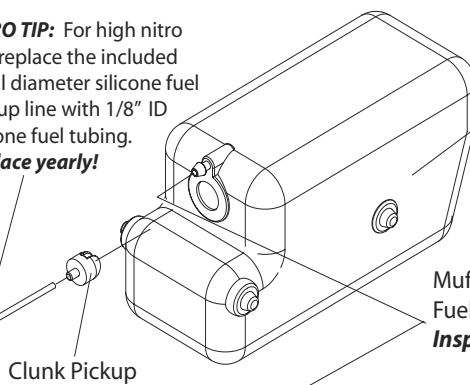

Clunk Pickup

Muffler Pressure Line: 1/8" Silicone Fuel Tubing (not included) **Inspect daily - replace yearly!**

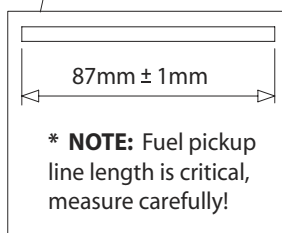

*** NOTE:** Fuel pickup line length is critical, measure carefully!

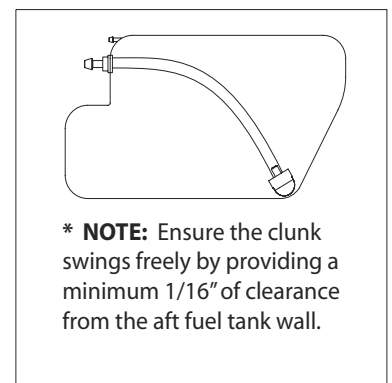

*** NOTE:** Ensure the clunk swings freely by providing a minimum 1/16" of clearance from the aft fuel tank wall.

2.1 SERVO-BOSS

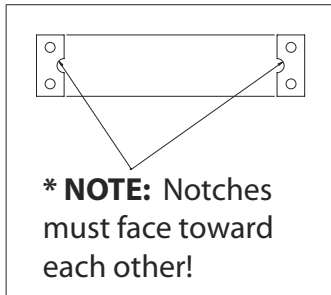

* **NOTE:** Do not glue the servo boss plates into place!

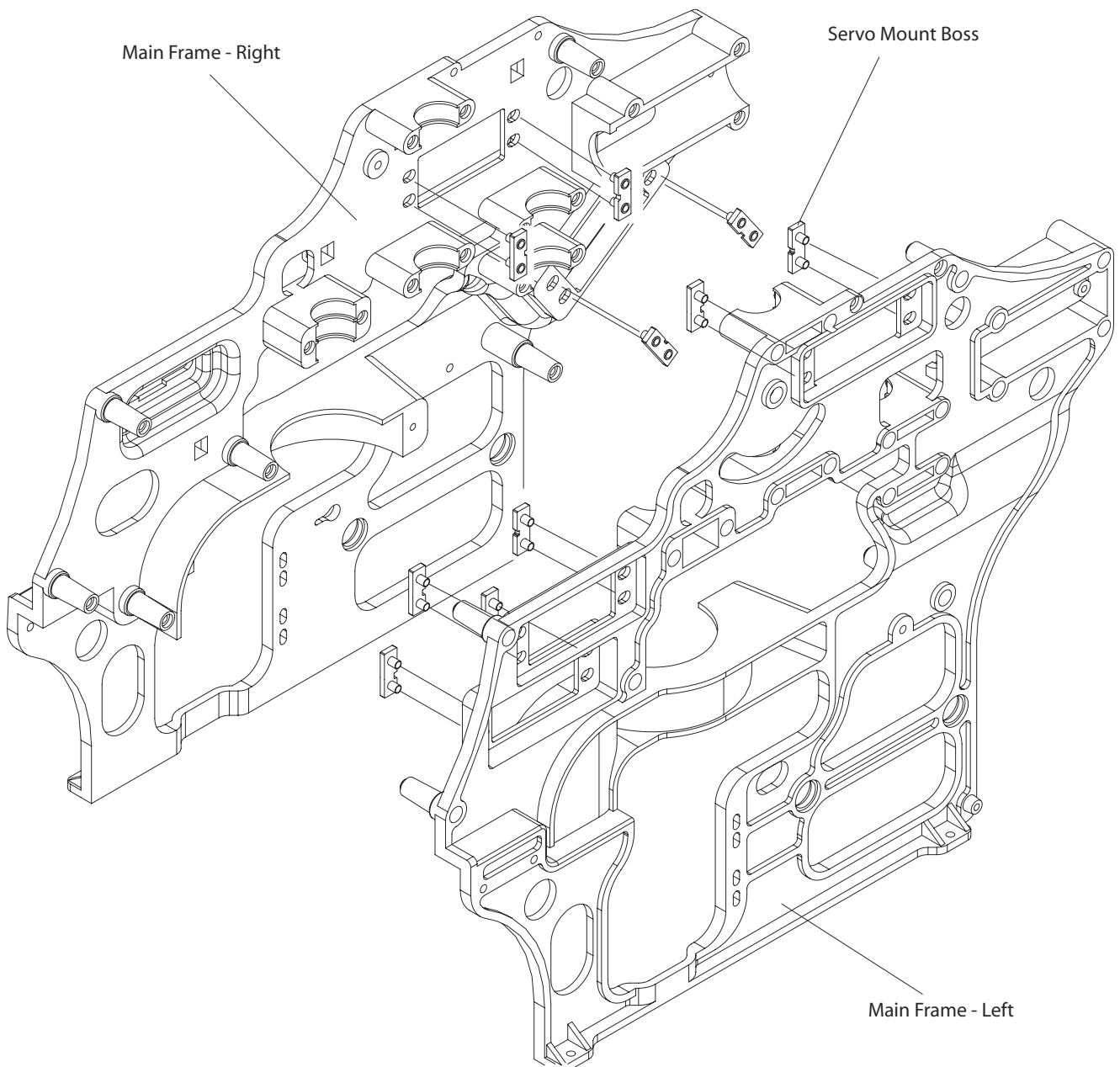

2.2 MAIN FRAME



M3x8mm Socket Head Bolt (x2)

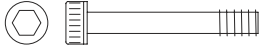

M3x38mm Socket Head Bolt (x16)



M3x12mm Socket Head Bolt (x1)



M3mm Nylon Lock Nut (x16)



Elevator Arm Bushing 32mm (x1)



Bearing L-1910ZZ (x2) - M10x19x7mm
Bearing L-1950ZZ (x1) - M5x19x6mm

*** PRO TIP:** add a small dab of silicone RTV at the four fuel tank mounting points when you assemble the fuel tank assembly into the main frame assembly.



*** NOTE:** Use care with thread locker!

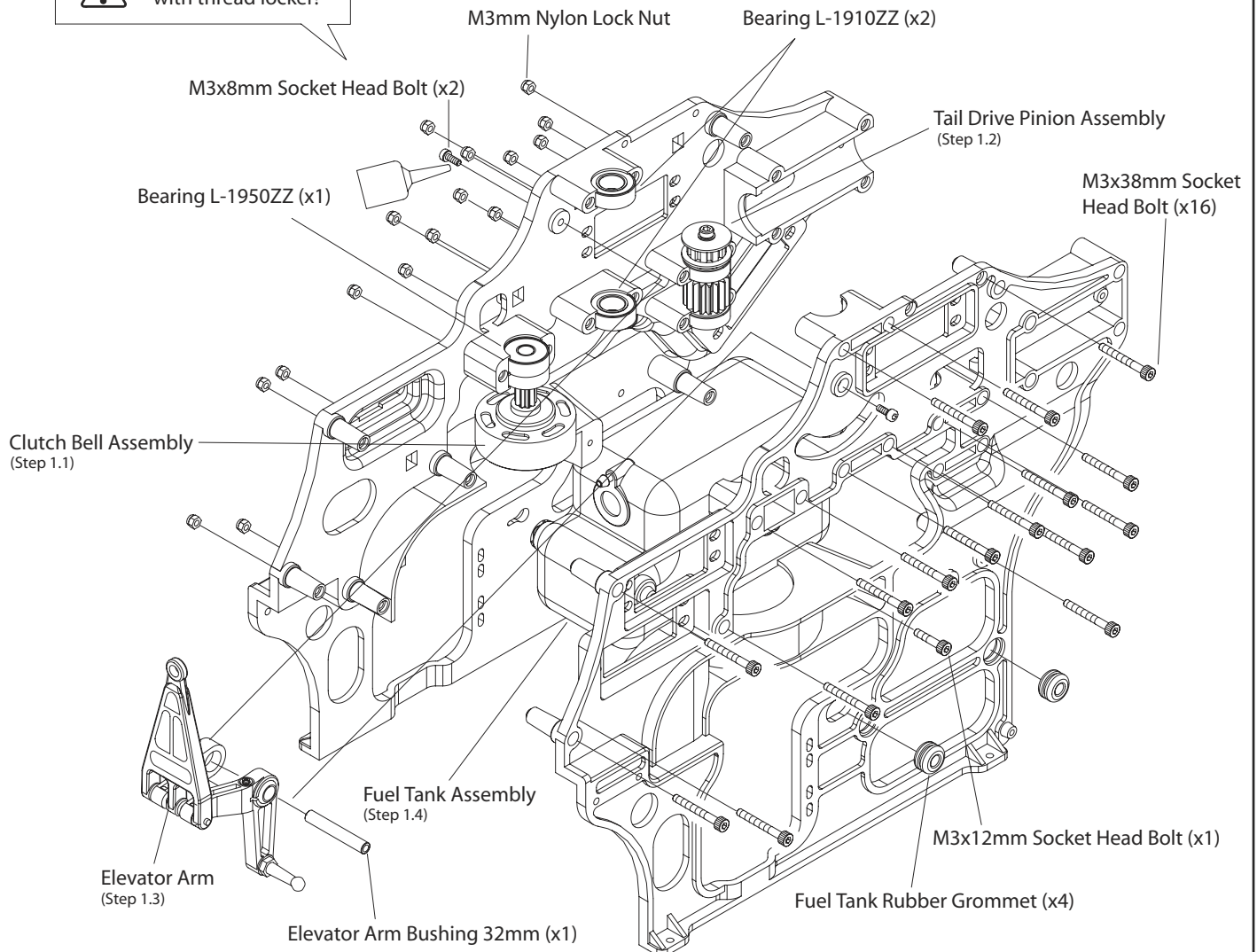

2.3 AVIONICS PLATFORMS

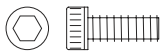

M3x10mm Socket head Bolt (x8)

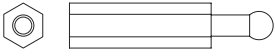

Cabin Mount Stand-off 20mm (x2)

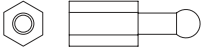

Cabin Mount Stand-off 10mm (x2)



M3x14 Set Screw (x2)



M3x12 Set Screw (x2)

Cabin Mount Stand-off
20mm (x2)

Gyroscope
Platform

M3x14 Set
Screw (x2)

M3x10mm Socket head Bolt (x8)

*** NOTE:** Don't use
thread locker on
plastic parts!

Radio Platform

M3x12 Set Screw (x2)

Cabin Mount Stand-off
10mm (x2)



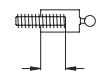

Cabin mount

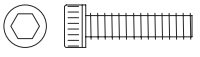

Use thread locker on
set screw, install it
evenly into standoff
and let it dry before
assembly to frame.

FRAME

3.1 LANDING GEAR

-  M3x15mm Socket Head Bolt (x4)
-  M3x6mm Set Screw (x4)
-  M3mm Nylon Lock Nut (x4)
-  M3mm Flat Washer (x8)

*** PRO TIP:** Use nylon zip-ties instead of socket head bolts and nylon lock nuts to secure landing gear struts to the main frame - this helps prevent greater damage in case you slam dunk your helicopter when practicing 3D.

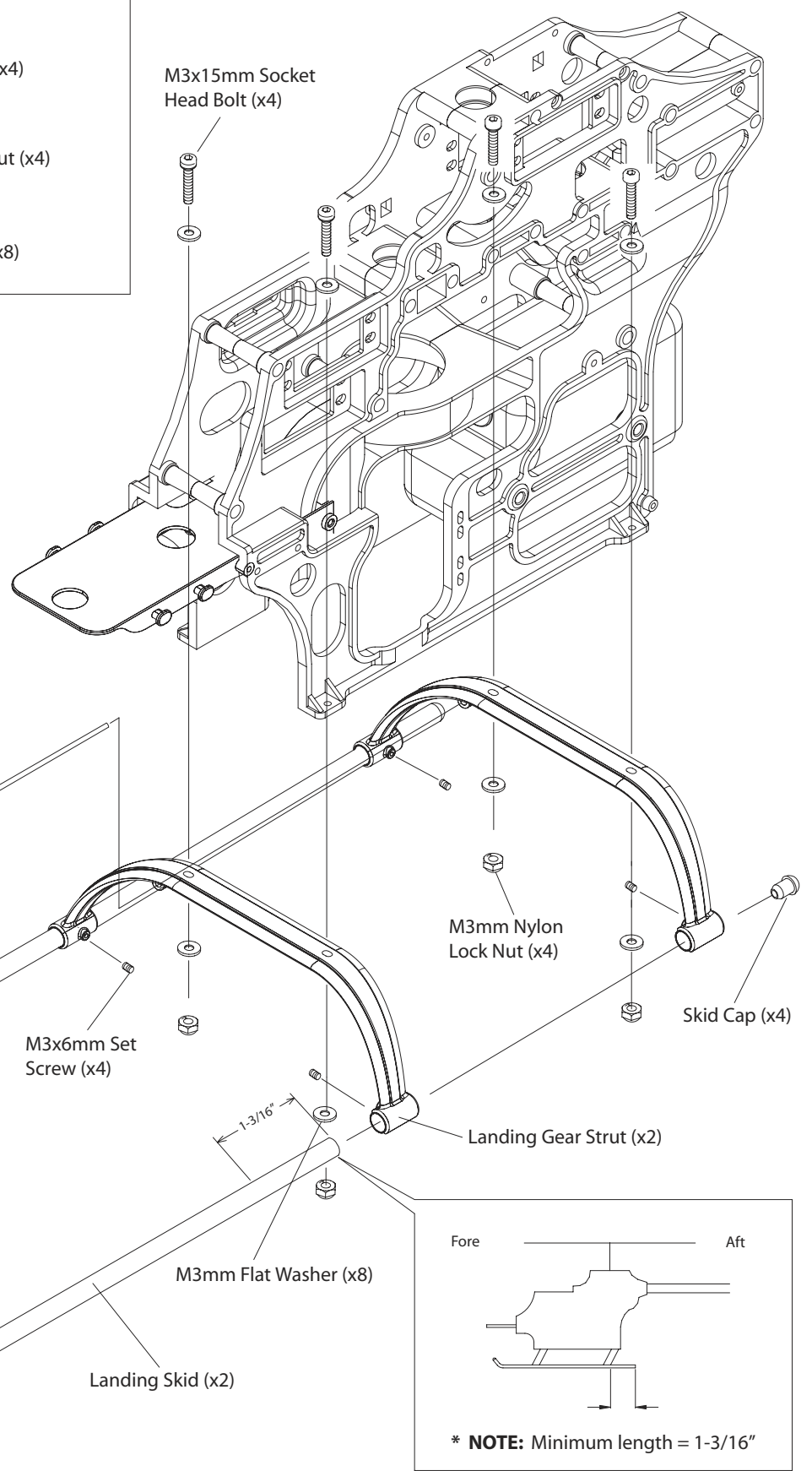

*** NOTE:** Use a small dab of silicone RTV as glue to help retain skid caps.

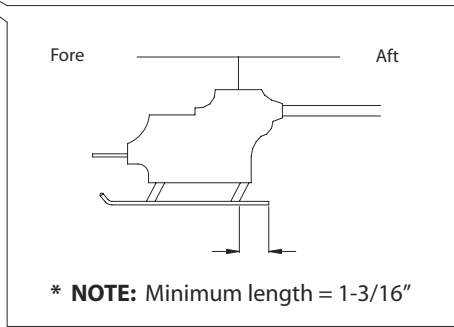

3.2 MAIN GEAR & SHAFT



M4x4mm Set Screw (x3)



M3x22 Socket Head Shoulder Bolt (x1)



M3mm Nylon Lock Nut (x1)

Mast Stopper

M4x4mm Set Screw (x3)

Long

Main Mast

Short



NOTE

Gently draw up the main mast to remove the slack.

Evenly tighten the M4x4 set screws in the mast stopper (use thread locker).

The beveled edge of the mast stopper faces the bearing.





Autoration Clutch

Nylon Lock Nut (x1)

M3x22 Socket Head Shoulder Bolt (x1)

* **PRO TIP:** The 89T - Main Gear (has 89-teeth) and when meshed with the 10T - Pinion Gear results in a 8.9:1 final drive ratio.

3.3 ENGINE MOUNT & FAN

-  M3x15mm Socket Head Bolts (x4)
-  M3x8mm Socket Head Bolts (x4)
-  M3mm Lock Washer (x4)
-  M3mm Flat Washer (x4)

*** PRO TIP:** Using a marker, place a dot on the clutch hub - then use a dial indicator to check for excessive runout. Time spend here may pay off in a smoother running helicopter. Simply loosening and rotating the assembly as little as a 1/8 turn can make a difference.

 *** NOTE:** Do not use thread locker on the crankshaft engine nut.

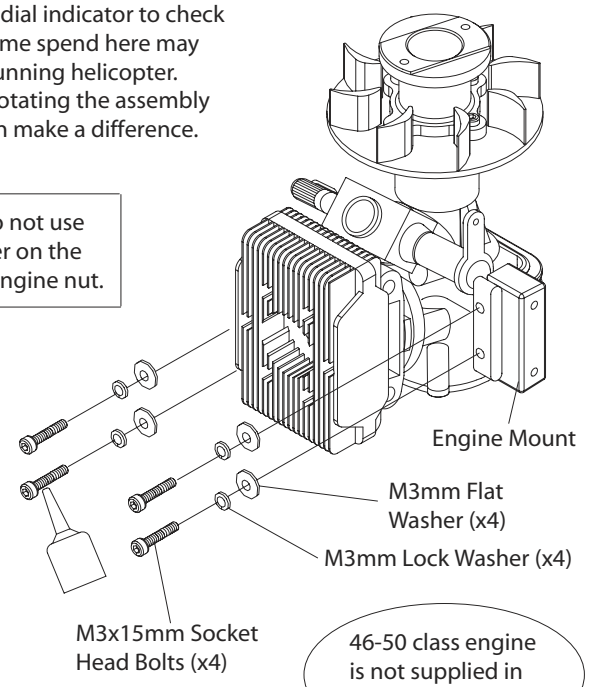



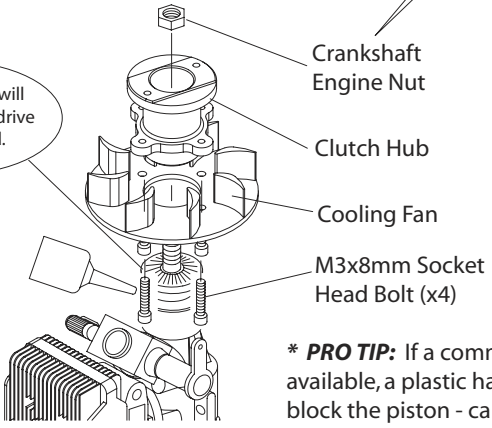

Not all engines will include a prop-drive yet it is required.

*** PRO TIP:** A 1/4" drive 10mm deep well thin wall socket is perfect for engine nut.

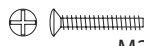

*** PRO TIP:** If a commercial piston-locking tool isn't available, a plastic handle from a toothbrush - used to block the piston - can aid in tightening the engine nut.

3.4 CLUTCH & EXTENSION

-  M2x8mm Phillips Head Screw (x1)
-  M3x8mm Socket Head Bolt (x2)
-  M2mm Hex Nut (x1)
-  Stainless Steel Ball Joint (x1)

*** PRO TIP:** Use a dial indicator to check for excessive runout. Beware false readings by measuring at the shoes. Take measurements at the hub. Try both rotating the assembly 180° or just loosening and tightening bolts as just that may make a difference.

Further details at:
www.audacitymodels.com

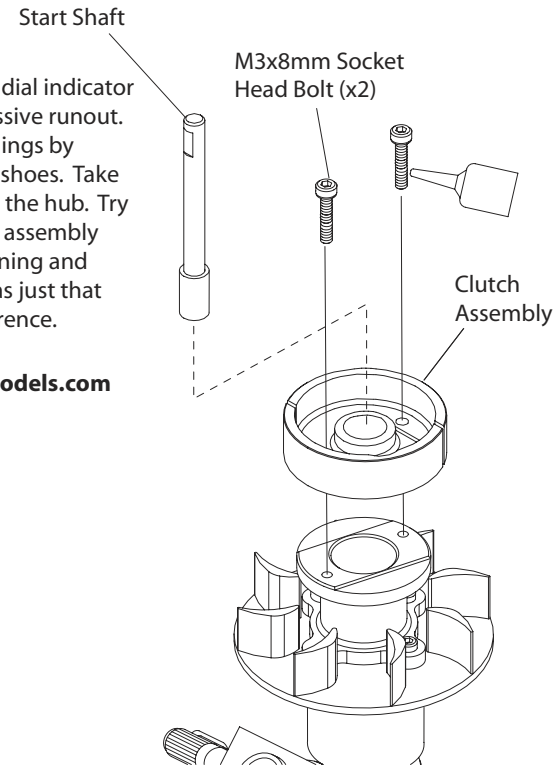
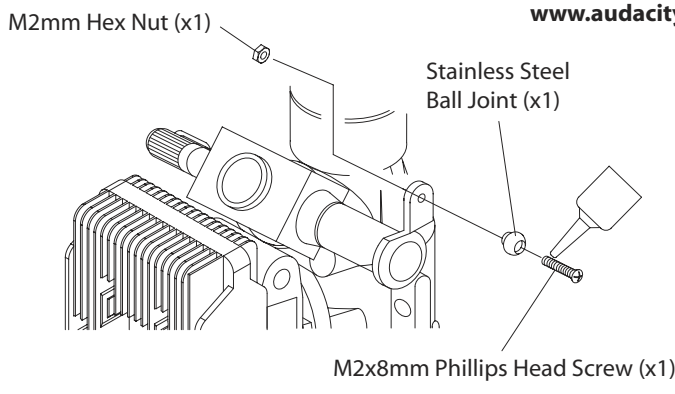

3.5 ENGINE & START SHAFT

 M3x12mm Socket Head Bolt (x4)

 M3mm Cap Bolt Holder (x4)



VERIFY

There is a slight amount of adjustment for the engine mount to fit within the main frames. This adjustment is for the purpose of aligning the clutch. The clutch **MUST** fit squarely within the clutch bell to ensure proper engagement of the clutch shoes against the friction material. Use care when fitting to align as well as possible.

* **PRO TIP:** Use a thin strip of typing paper wrapped once around clutch for alignment.

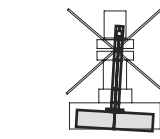

Angled - INCORRECT

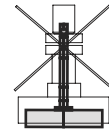

Too Low - INCORRECT

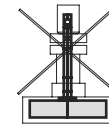

Too High - INCORRECT

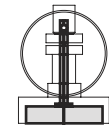

CORRECT

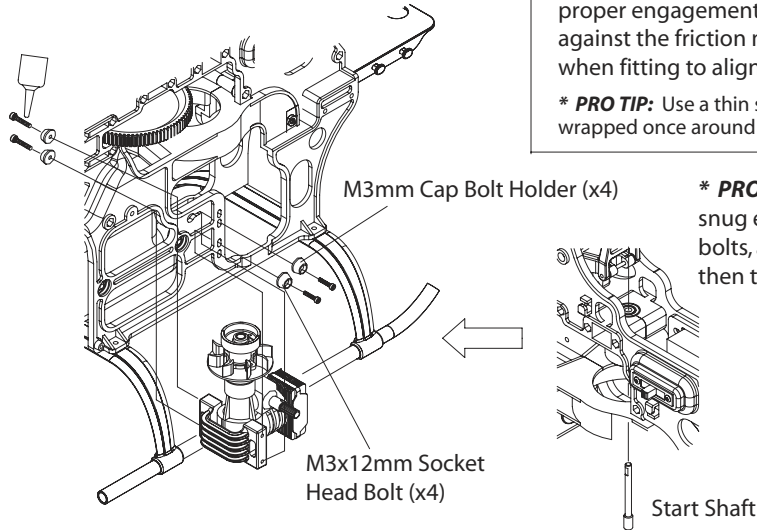

3.6 HEX ADAPTER/MUFFLER

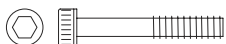
 M3x30mm Socket Head Bolt (x2)

 M4x4mm Set Screw (x1)

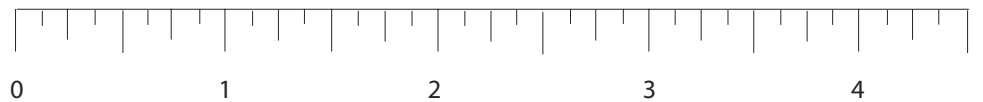

Hex Start Adapter

* **NOTE:**
Tighten set screw
against start shaft's flat.

M4x4mm Set Screw (x1)



* **VERIFY:** Muffler pressure and fuel feed 1/8" silicone rubber tubing is a maintenance item. Inspect daily.

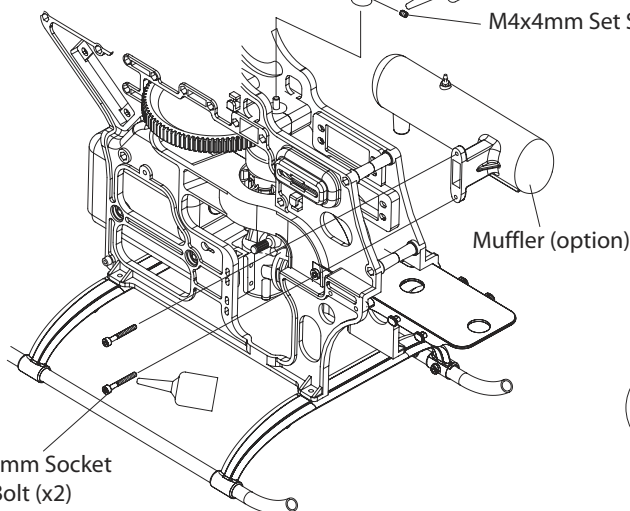

M3x30mm Socket Head Bolt (x2)

* **NOTE:** Slide muffler mounting bolts into engine crankcase before mounting engine to the main frame.

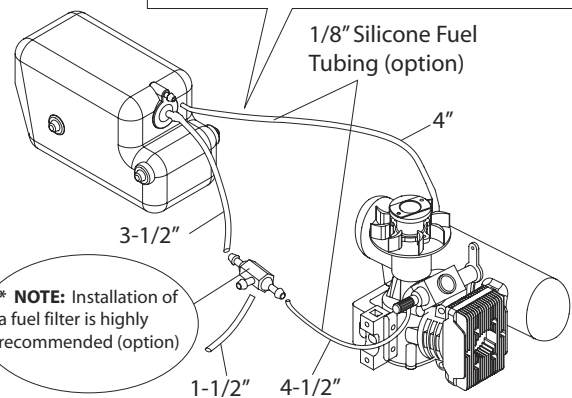

* **NOTE:** Installation of a fuel filter is highly recommended (option)

4.1 SWASHPLATE/WASHOUT

*** PRO TIP:** Lubricate the washout slider with a few drops of light machine oil such as 3-in-1 daily.



VERIFY

The washout links must connect to the two longer-stud balls on the swashplate inner ring.

*** PRO TIP:** For extreme performance, or 3D flight, extend both of the short inner balls to match the length of the longer balls.

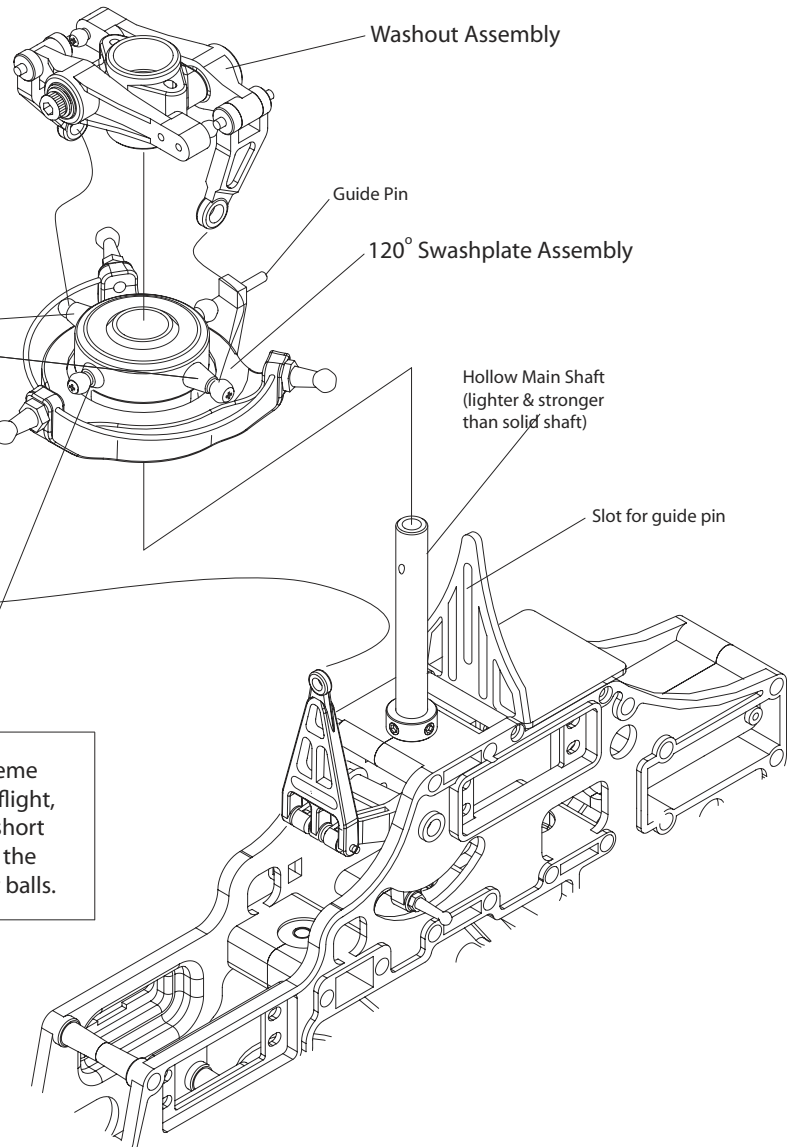

Greater Stability - inner holes of washout mixing arms.

Greater Agility - outer holes of washout mixing arms.

Complete Assembly

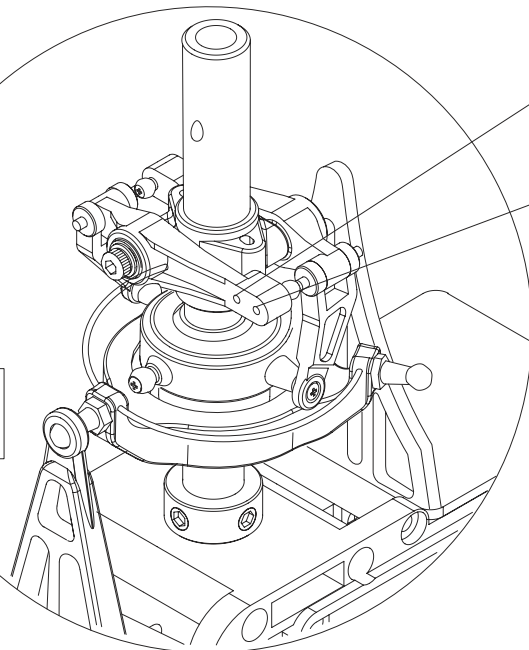

4.2 HEAD & FLYBAR ARM

 M3x20mm Socket Head Shoulder Bolt (x1)

 M3mm Nylon Lock Nut (x1)

 M2x10mm Phillips Head Screw (x2)

 M3x5mm Set Screw (x2)

 Stainless Steel Ball (x2)

*** PRO TIP:** This shoulder bolt is also known as a Jesus bolt.

M3x5mm Set Screw (x2)
M3x20mm Socket Head Shoulder Bolt (x1)

Rotor Head Assembly

Fly Bar Stopper

M3mm Nylon Lock Nut (x1)

M2x10mm Phillips Head Screw (x2)

Stainless Steel Ball (x2)

*** NOTE:** Ensure the rotor hub pin engages the washout base groove before securing the rotor head onto the main shaft.

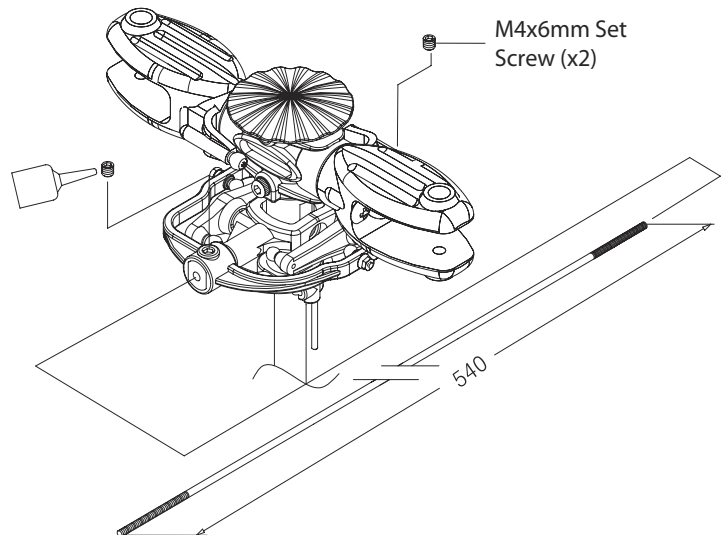
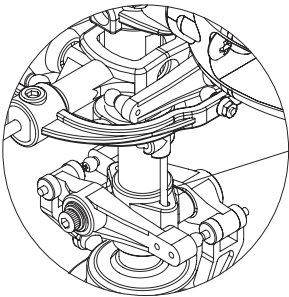

M4x6mm Set Screw (x2)

540

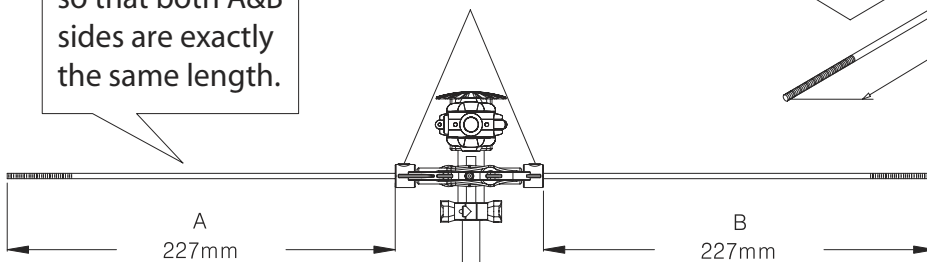

*** NOTE:** Adjust so that both A&B sides are exactly the same length.



A
227mm

B
227mm

4.4 FLYBAR PADDLES

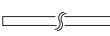
-  M3mm Nylon Locking Nut (x2)
-  M4x6mm Set Screw (2)
-  3x70mm weight (x2)

* **NOTE:** Both flybar paddles plus the flybar control arm should (all three) be perfectly parallel to each other.

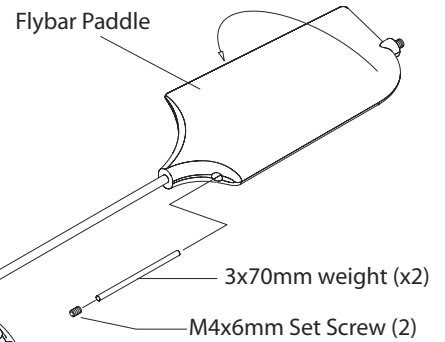

* **PRO TIP:** For greater agility, don't install the weight inside the flybar paddles.

* **NOTE:** Flybar paddles - short leading edge section forward - clockwise rotation.

M3mm Nylon Locking Nut (x2)

5mm



VERIFY

Thread each flybar paddle onto flybar until 5mm of threaded rod protrudes beyond the end.

4.5 ROTOR CONTROL RODS

A - Seesaw Arm to Main Blade Grip

- (A) M2.3x13mm Threaded Rod (x2)
SHORT - HD Ball Link Ends (x2)

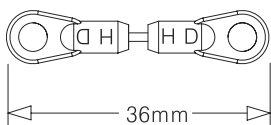

B - Washout Arm to Flybar Control

- (B) M2.3x13mm Threaded Rod (x2)
LONG - HD Ball Link Ends (x2)

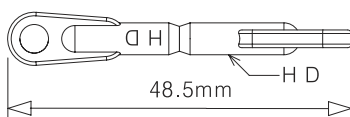

C - Swashplate to Seesaw Arm

- (C) M2.3x40mm Threaded Rod (x2)
LONG - HD Ball Link Ends (x2)

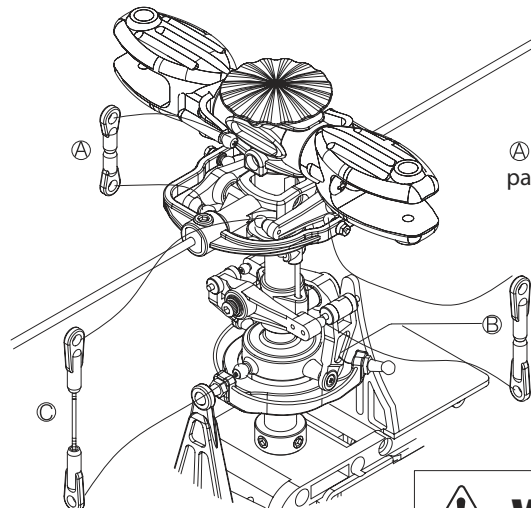
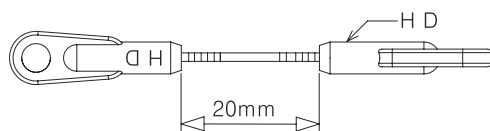

WARNING

The HD Ball Link Ends are designed to fit one way only. Snap the HD link over the ball with the HD facing outward - away from the ball.

5.1 TAIL GEAR BOX & BELT

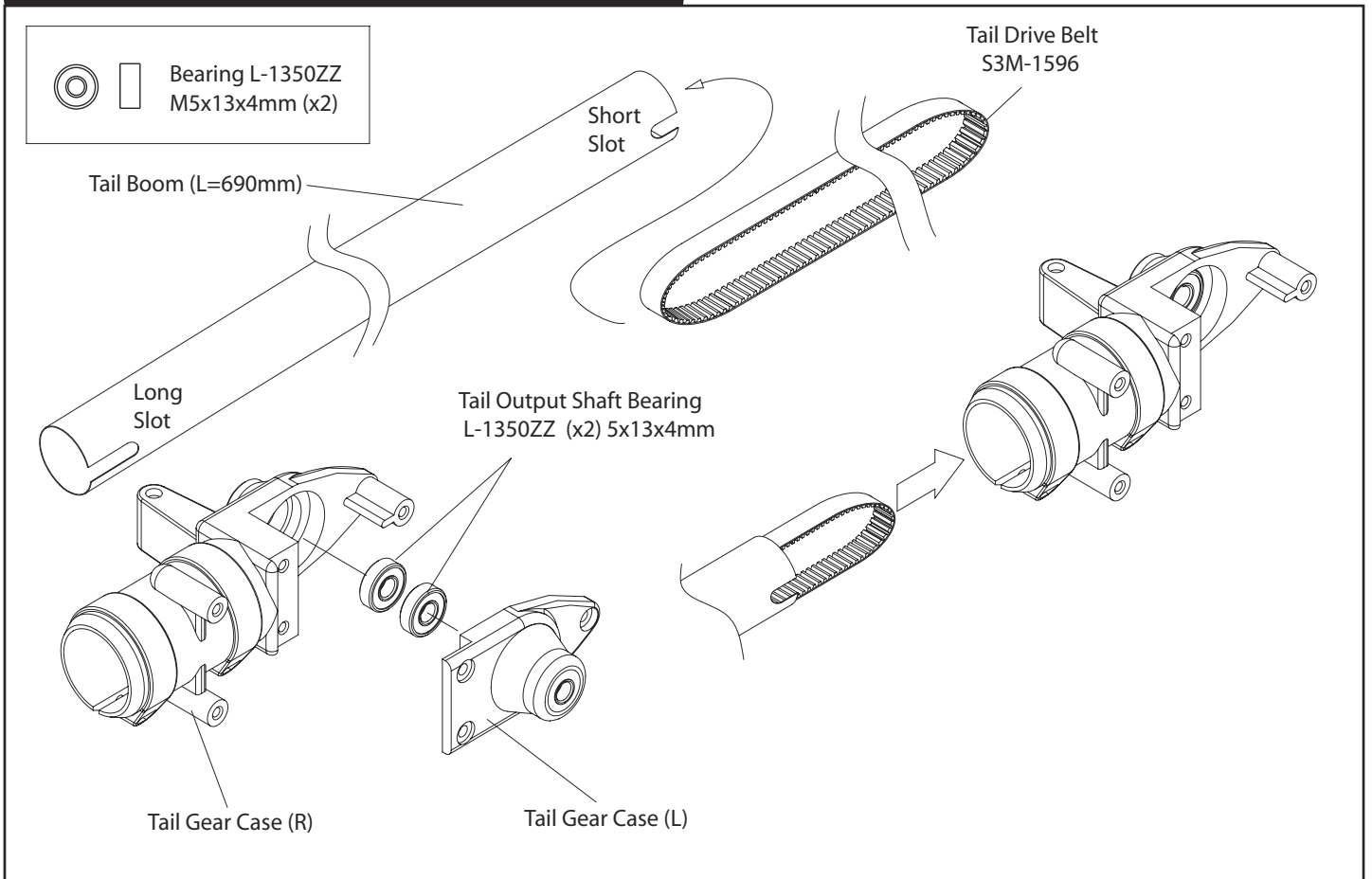

5.2 TAIL OUTPUT SHAFT

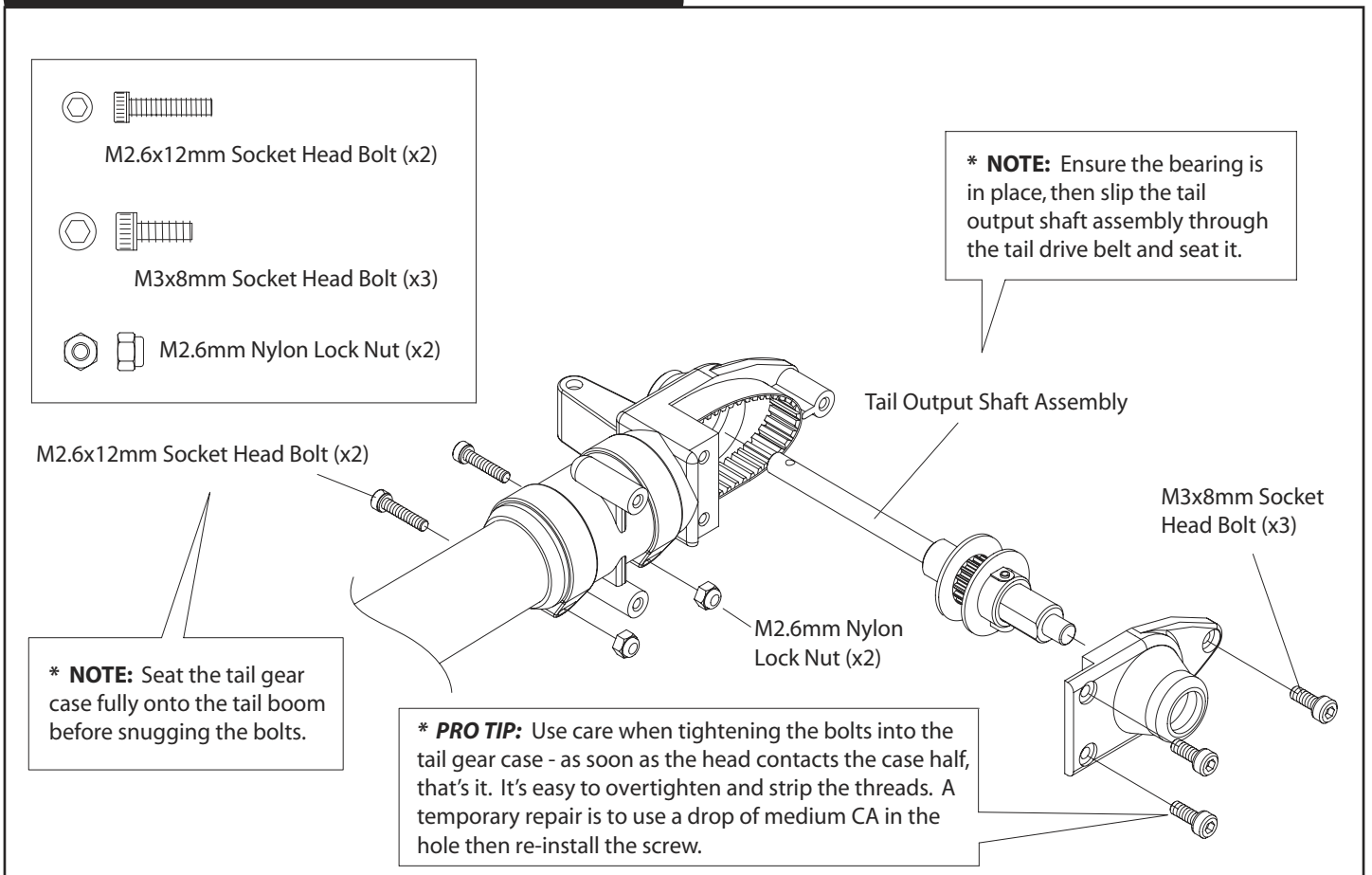



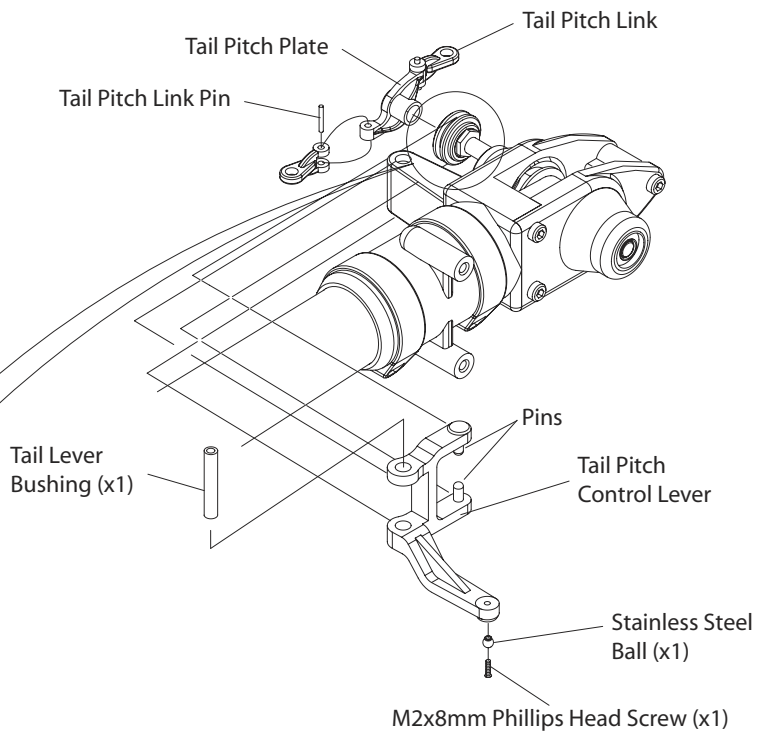
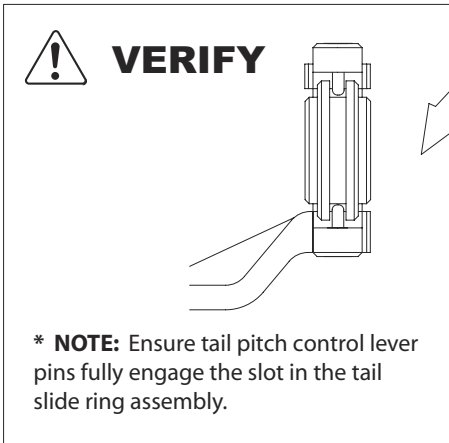
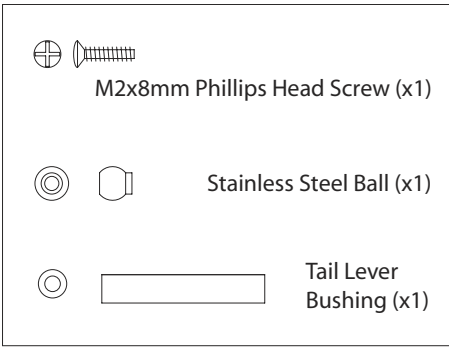

5.3 TAIL PITCH LEVER

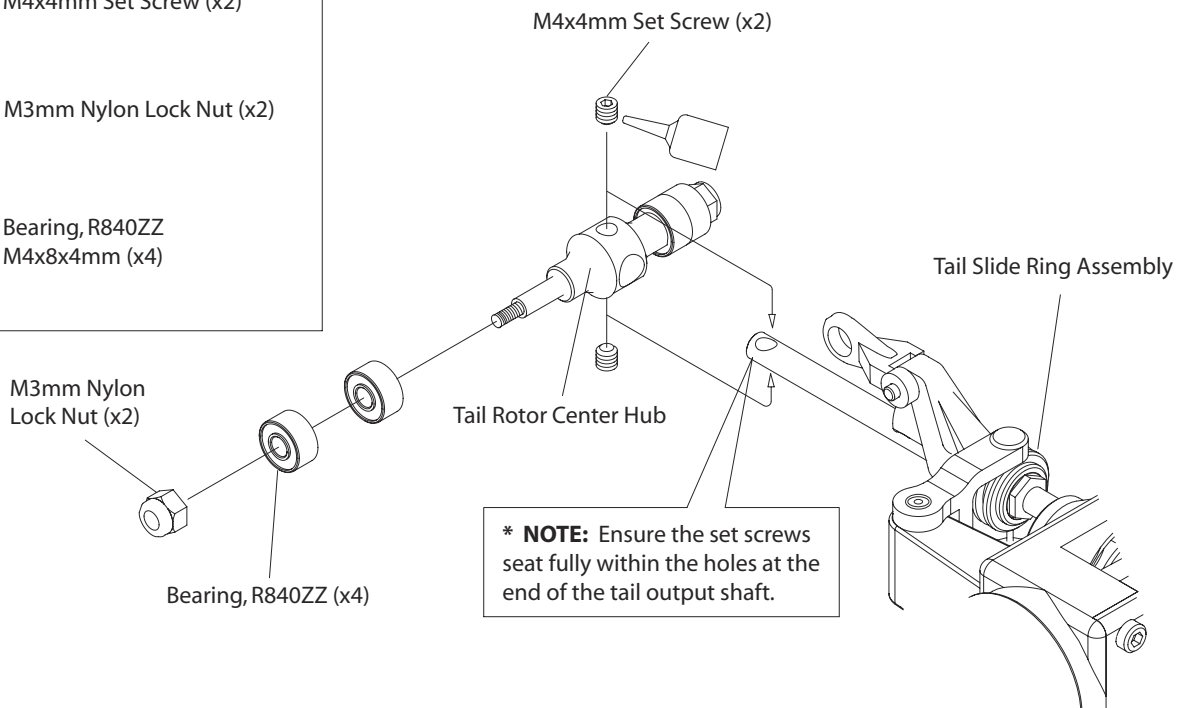
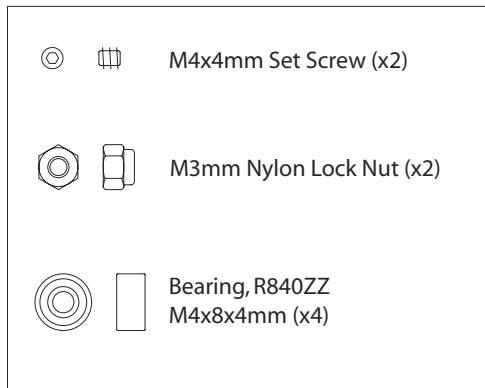

5.4 TAIL ROTOR HUB



5.5 TAIL ROTOR GRIP

-  M2x8mm Phillips Head Screw (x2)
-  M2x8mm Socket Head Bolt (x4)
-  M3x15mm Socket Head Bolt (x2)
-  M2mm Hex Nut (x4)
-  M3mm Nylon Lock Nut (x2)
-  Stainless Steel Ball (x2)

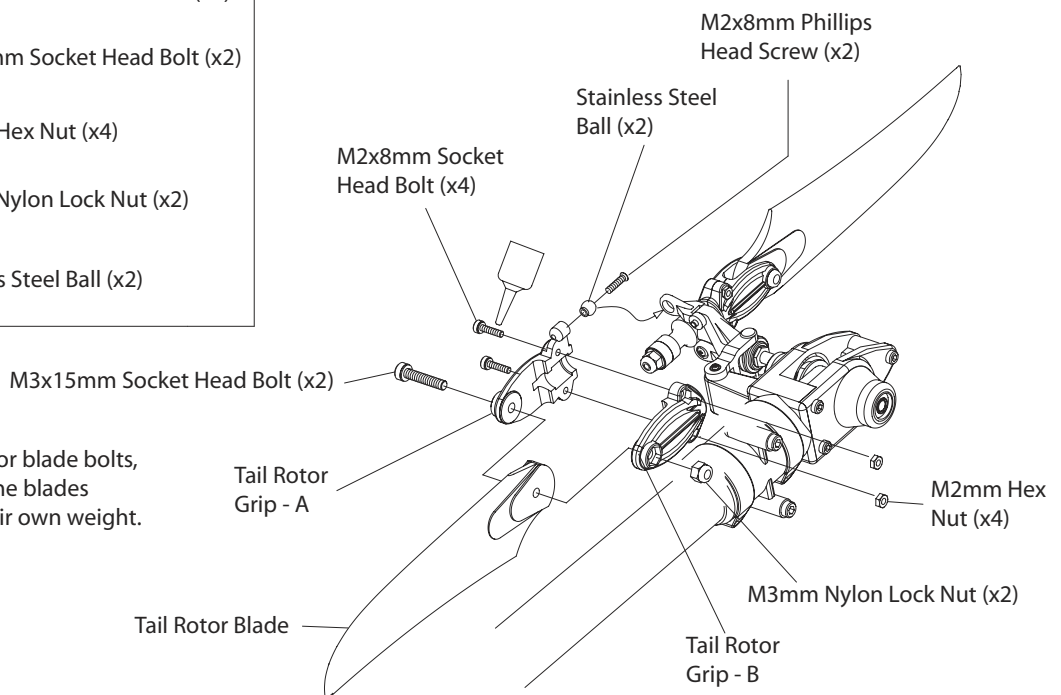

* **PRO TIP:** Snug the tail rotor blade bolts, but don't tighten so much the blades don't swing freely under their own weight.

5.6 VERTICAL FIN

-  M3x10mm Socket Head Bolt (x2)

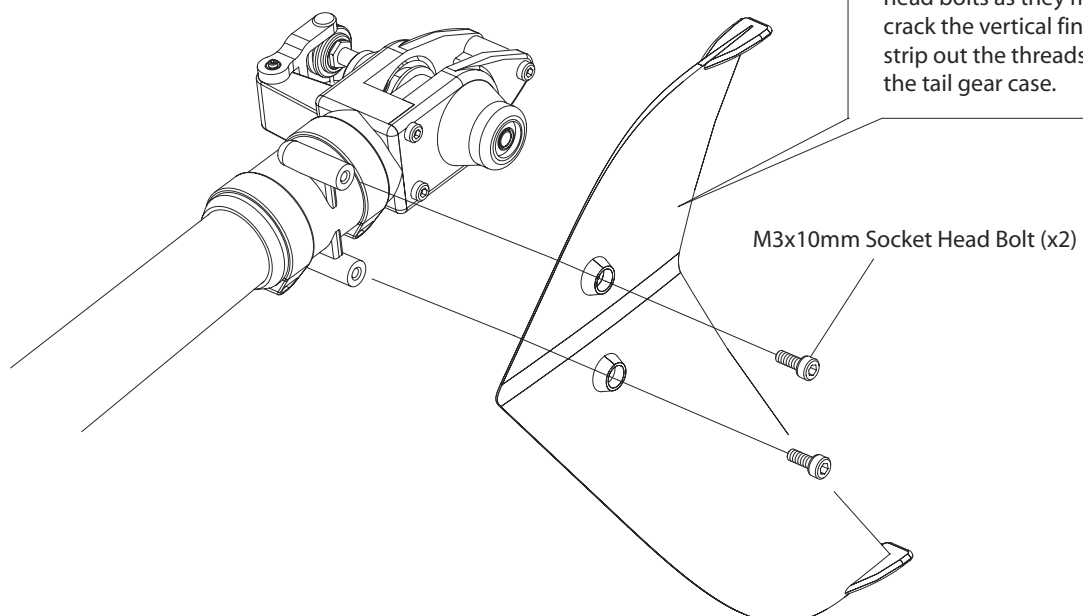

* **NOTE:** Use care to not overtighten the socket head bolts as they may crack the vertical fin or strip out the threads in the tail gear case.

5.7 TAIL BOOM ASSEMBLY

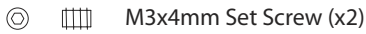
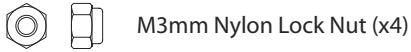
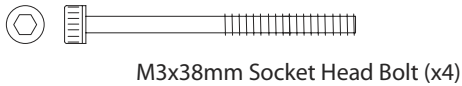

* **NOTE:** Ensure the orientation and the tension of the tail drive belt are correct. Verify the tail rotor output shaft is perpendicular to the main shaft by sighting from behind. Then set the tension in the belt as noted below and tighten both the bolts in the main frame plus the set screws securely against the tail boom.

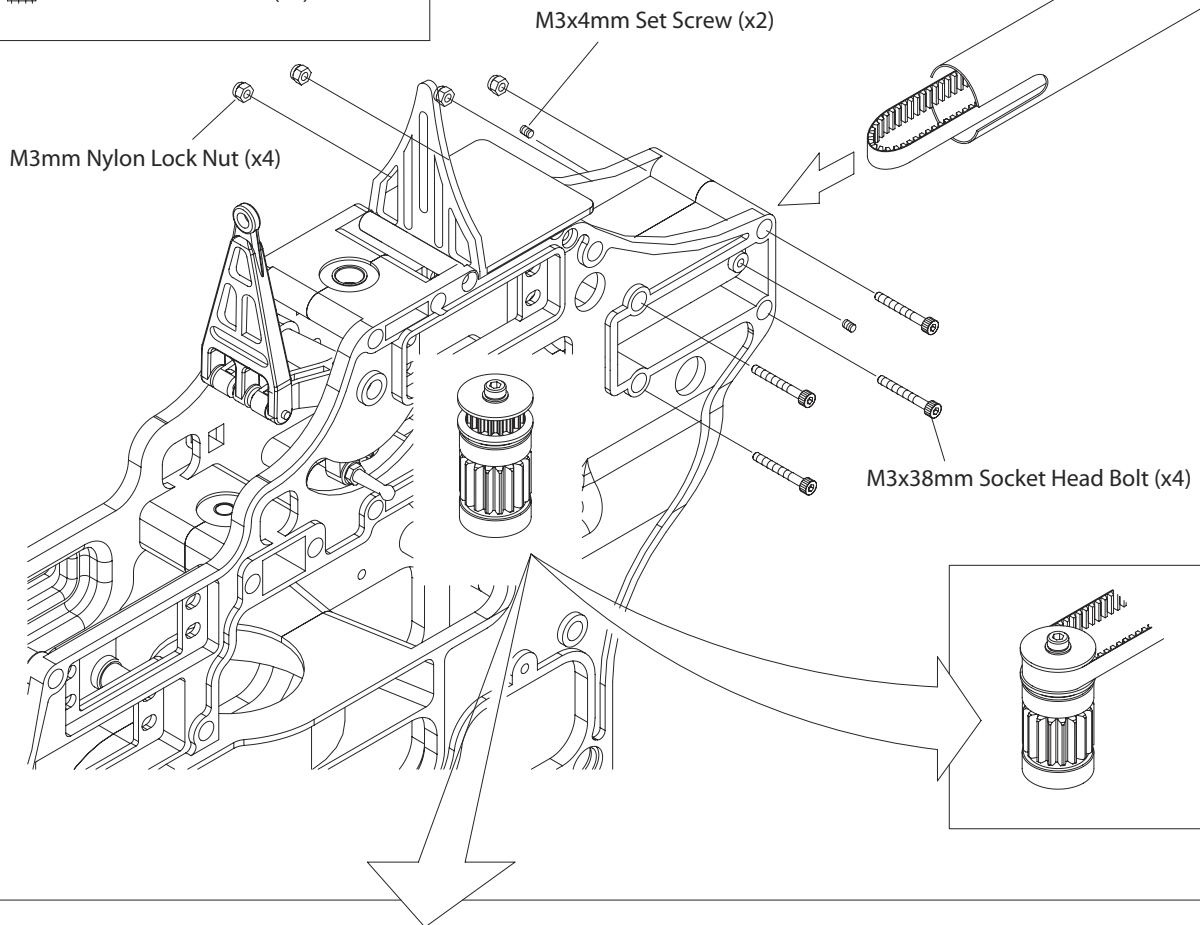
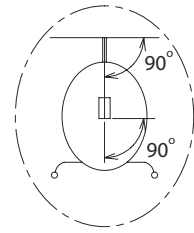

VERIFY

TENSION: Ensure there is a little slack in the tail rotor drive belt. Reach in with your fingertip, or with the tip of a screwdriver, and push one side against the other. They should almost touch without great effort.

ORIENTATION: The tail drive belt must be oriented correctly to ensure the proper rotation of the tail rotor output shaft. There is a 90° clockwise twist when viewed from the front of the tail boom assembly.

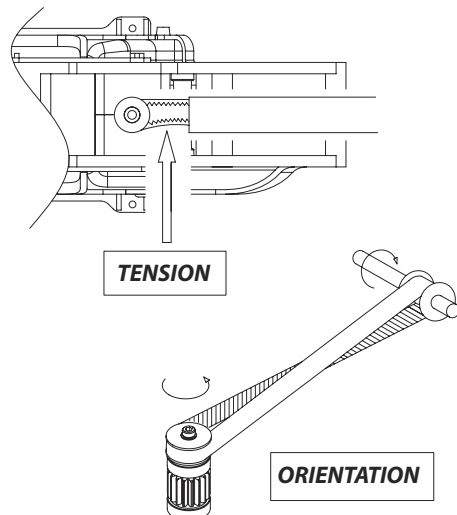

5.8 TAIL BOOM SUPPORTS

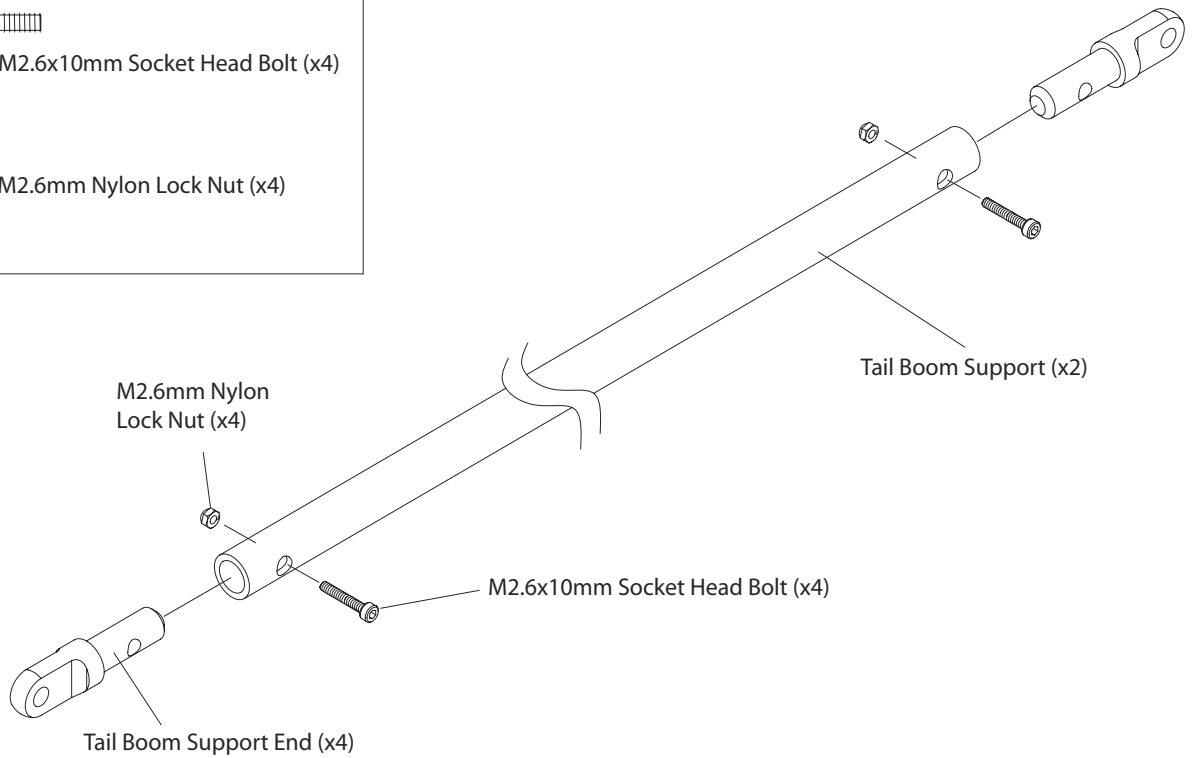
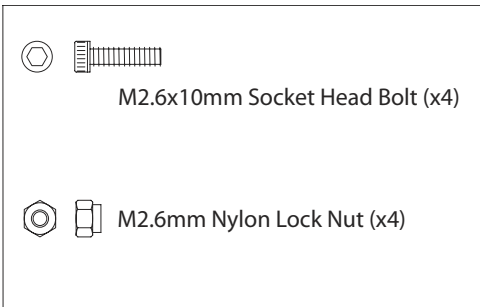

5.9 BOOM SUPPORT CLAMP

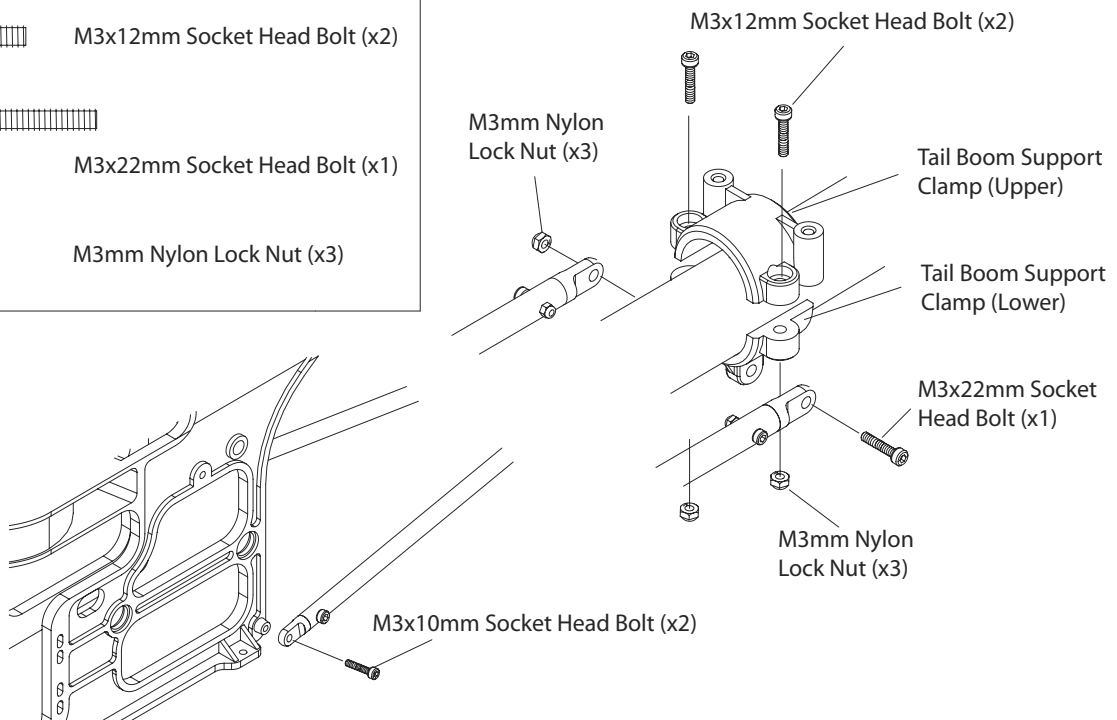
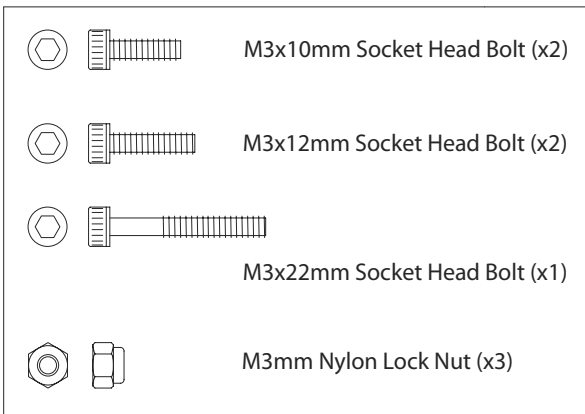

6.1 SERVO INSTALLATION



M2.6mm Flat Washer (x12)



M2.6x10mm Self Tapping Screw (x12)



Round Rubber Grommet (x2)

Round Rubber Grommet (x2)

Receiver Switch

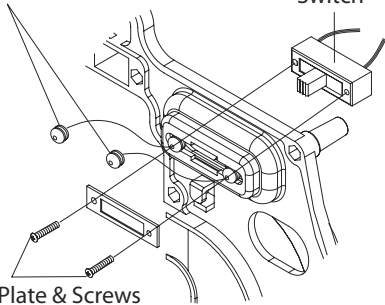

Switch Plate & Screws

*** NOTE:** Do not overtighten screws.

*** PRO TIP:** Due to the sharing of the flight loads between the three swashplate servos used by an eCCPM system, the individual servos do not have to be tremendously strong. The Tiger 50 has been extensively flown with standard 40-oz ball bearing servos - with excellent results. However, extreme performance pilots will notice a nice improvement when upgrading to digital servos. In order of importance, upgrade to digital on the tail rotor first, then the swashplate servos.

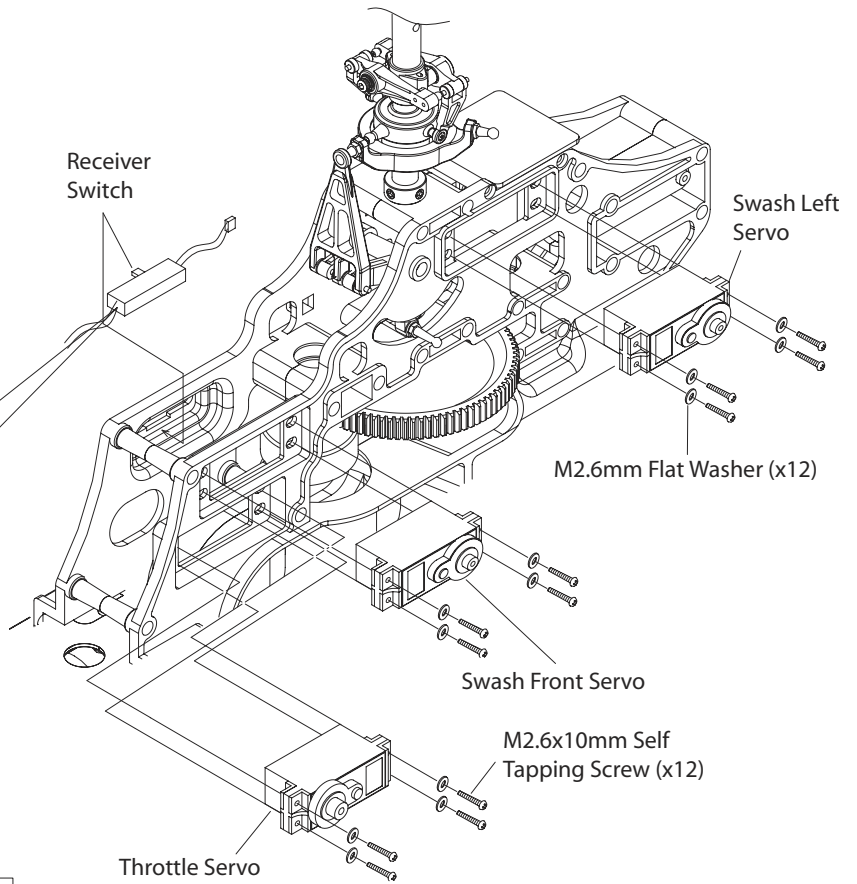

M2.6mm Flat Washer (x12)

Rudder Servo

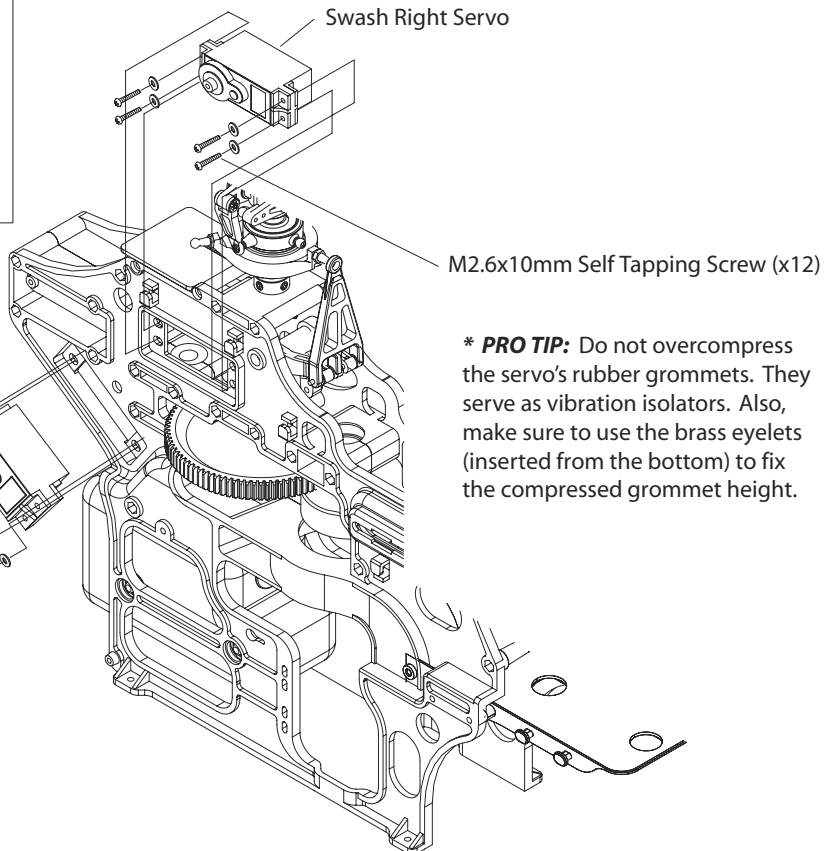

*** PRO TIP:** Do not overcompress the servo's rubber grommets. They serve as vibration isolators. Also, make sure to use the brass eyelets (inserted from the bottom) to fix the compressed grommet height.

6.2 TAIL ROTOR PUSHROD

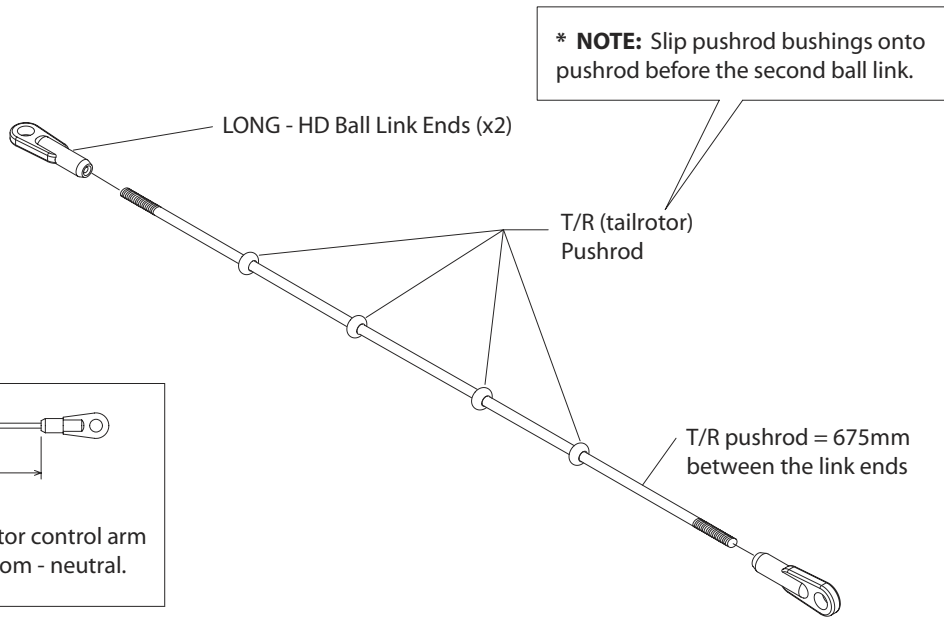
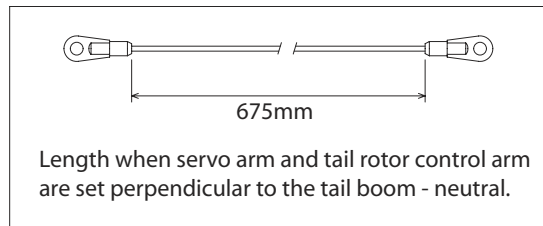
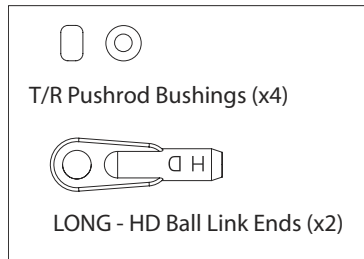

6.3 T/R PUSHROD GUIDES

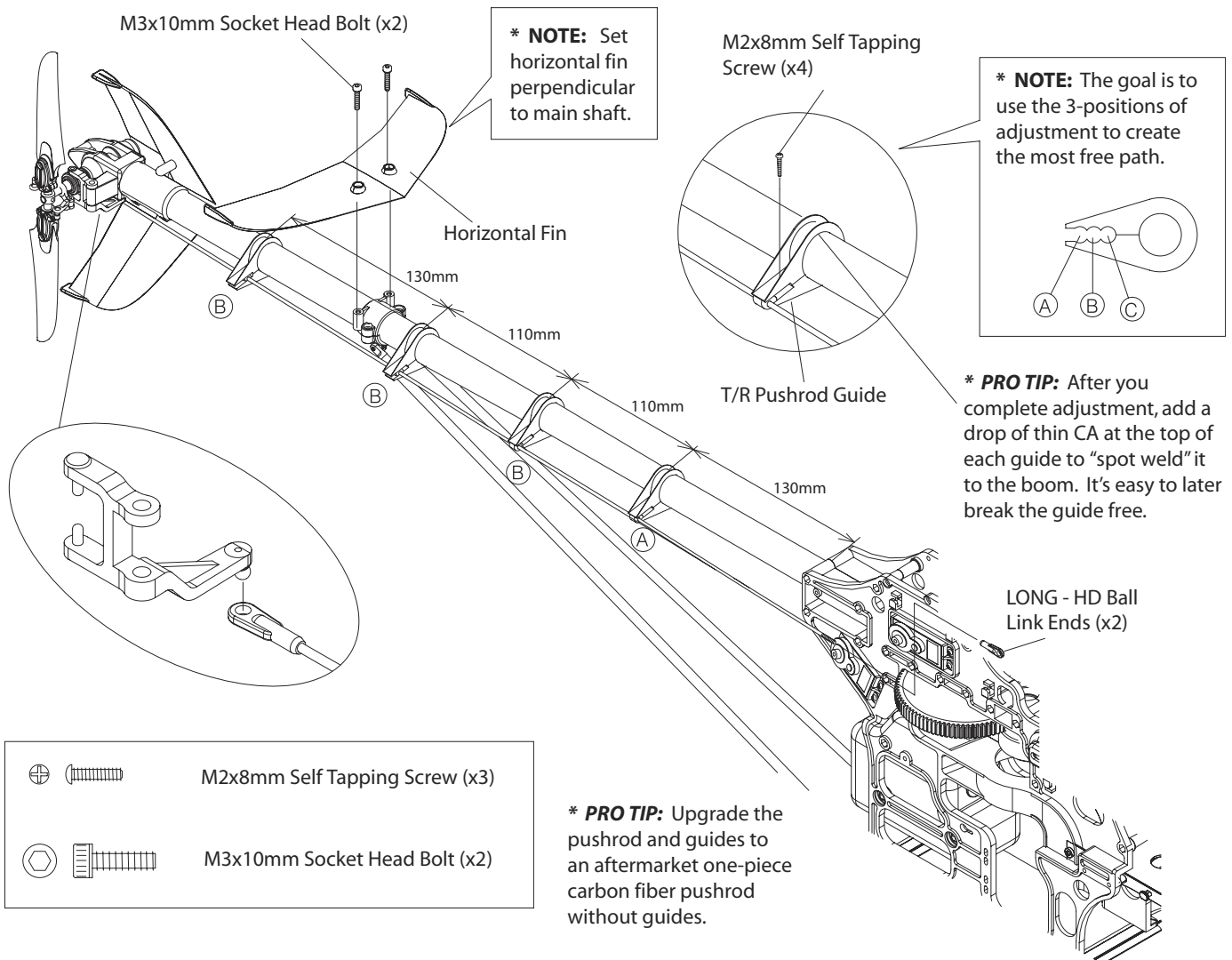

6.4 AVIONICS ISOLATION



CAUTION

The importance of protecting the avionics package (receiver, gyro amplifier, governor, and battery pack) from the primary vibrations caused by the engine and the secondary vibrations induced by the main and tail rotors cannot be overemphasized. These forces may lead to premature failure of the avionics components leading to intermittent or permanent loss of control and possibly property damage, injury, or even death. Use a high quality wrap such as Du-Bro No. 514 - 1/2" (12.7mm) thick foam rubber. Do not use plastic bubble-wrap, open-cell foam, or servo tape for mounting these delicate components.

*** PRO TIP:** The gyroscope platform should be cleaned by lightly wiping down with acetone before using the mounting tape supplied by the gyroscope manufacturer.

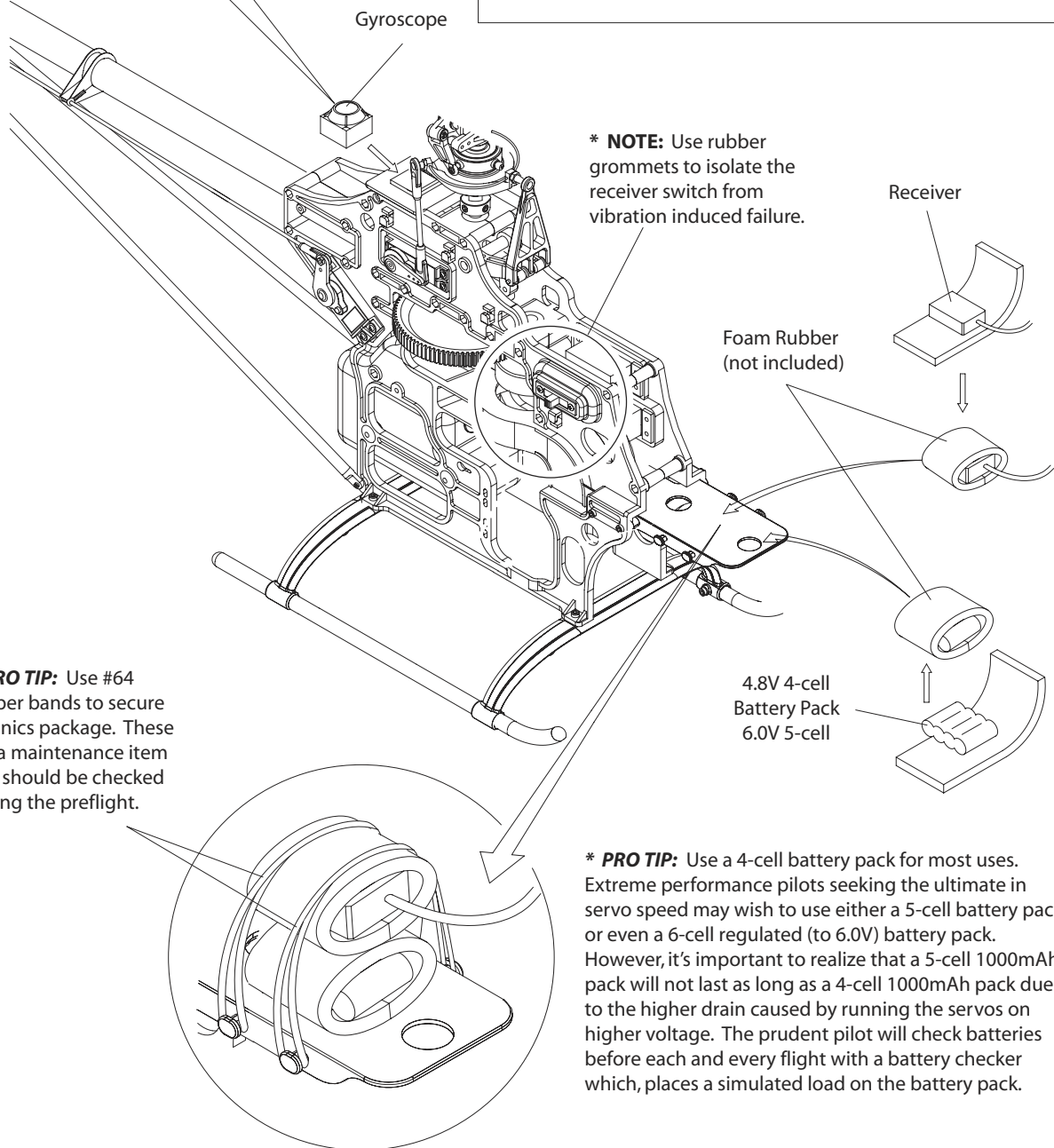

*** NOTE:** Use rubber grommets to isolate the receiver switch from vibration induced failure.

Receiver



Foam Rubber
(not included)

4.8V 4-cell
Battery Pack
6.0V 5-cell

*** PRO TIP:** Use #64 rubber bands to secure avionics package. These are a maintenance item and should be checked during the preflight.

*** PRO TIP:** Use a 4-cell battery pack for most uses. Extreme performance pilots seeking the ultimate in servo speed may wish to use either a 5-cell battery pack, or even a 6-cell regulated (to 6.0V) battery pack. However, it's important to realize that a 5-cell 1000mAh pack will not last as long as a 4-cell 1000mAh pack due to the higher drain caused by running the servos on higher voltage. The prudent pilot will check batteries before each and every flight with a battery checker which, places a simulated load on the battery pack.

7.1 LINKAGES (PORT)

-  M2x8mm Phillips Head Screw (x3)
-  M2 Hex Nut (x3)
-  Stainless Steel Ball (x3)

(B) 2.3x50mm Threaded Rod **ELEVATOR**

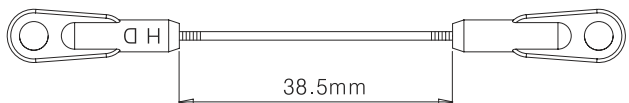

38.5mm

SWASHPLATE
Ball at 20mm

ELEVATOR
Ball at 20mm

SERVO ARMS

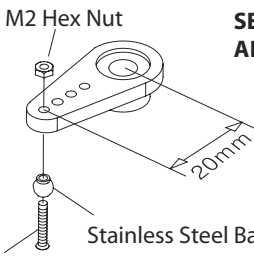

M2 Hex Nut

M2x8mm Phillips Head Screw

Stainless Steel Ball

20mm

2.3x50mm Threaded Rod

(C)

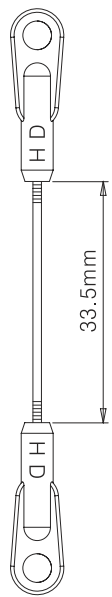

33.5mm

THROTTLE

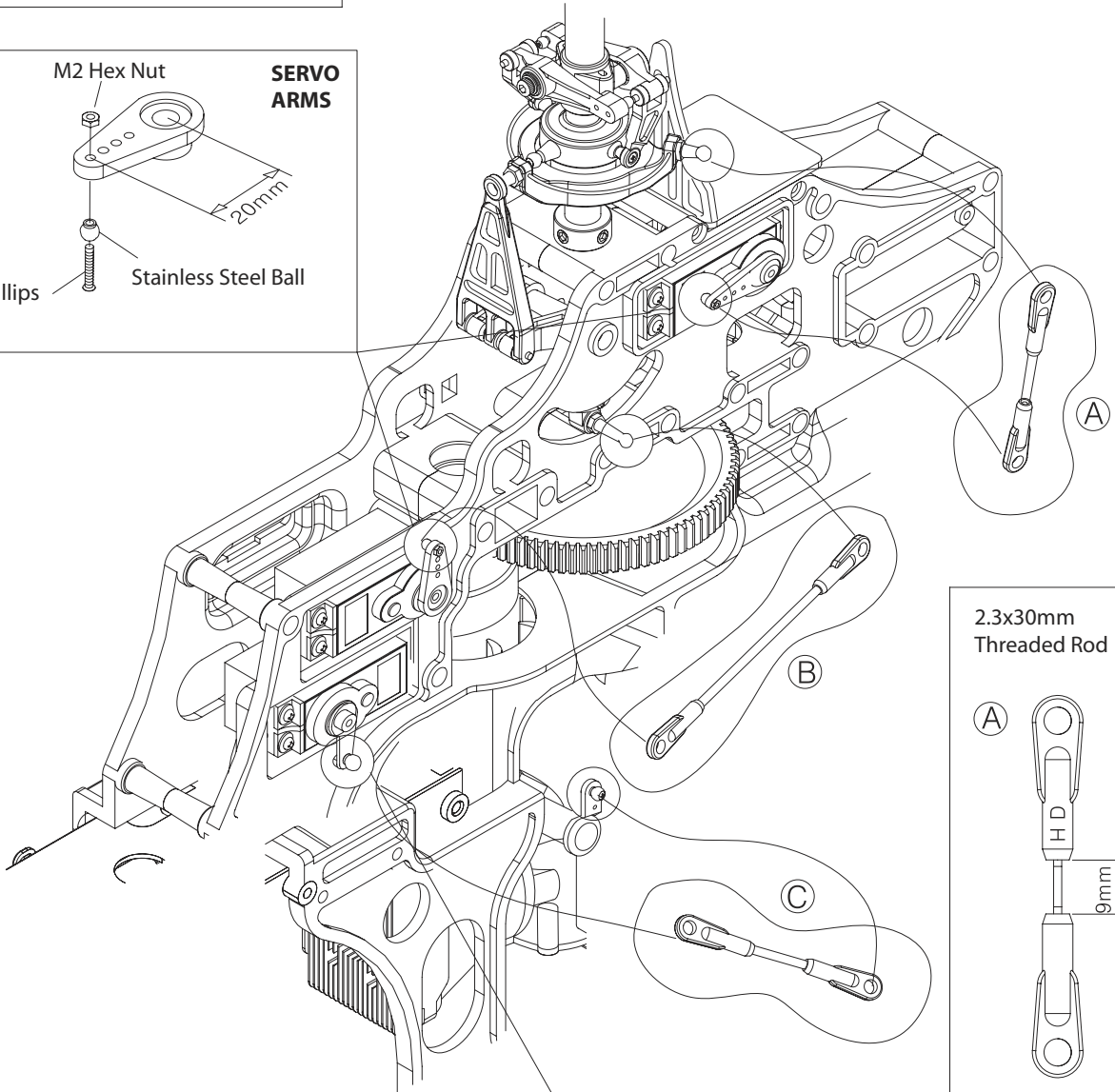

2.3x30mm Threaded Rod

(A)

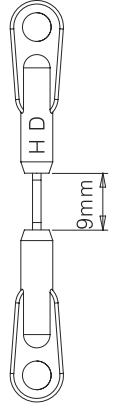

9mm

SWASHPLATE

*** NOTE:** Use thread locker on servo arm ball screws.

*** PRO TIP:** The goal is to avoid differential throw by ensuring a symmetrical throw from wide open throttle (WOT) to idle position (IP) instead of closed throttle (CT). Neutral (N) is mid-throttle stick (half throttle = hover); all arms are perpendicular to the pushrod.

THROTTLE LINKAGE SETUP

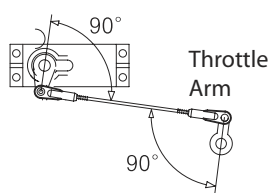

90°

Throttle Arm

90°

MID T/C STICK IS NEUTRAL

M2x8mm Phillips Head Screw (x3)

Stainless Steel Ball (x3)

THROTTLE
Ball at 12.5mm

SERVO ARM

M2 Hex Nut (x3)

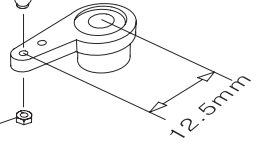

12.5mm

7.2 LINKAGES (STARBOARD)

Ⓓ M2.3x40mm Threaded Rod

SWASHPLATE

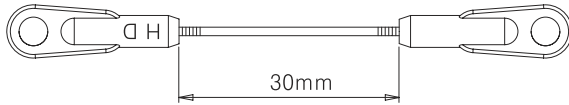

⊕ M2x8mm Phillips Head Screw (x2)

⊙ M2mm Hex Nut (x2)

⊙ Stainless Steel Ball (x2)

SWASH SERVO ARM

M2mm Hex Nut

M2x8mm Phillips Head Screw

Stainless Steel Ball

20mm

M2mm Hex Nut

T/R SERVO ARM

M2x8mm Phillips Head Screw

Stainless Steel Ball

12.5mm

*** NOTE:** Use thread locker on servo arm ball screws.

TAIL ROTOR PITCH CONTROL LEVER

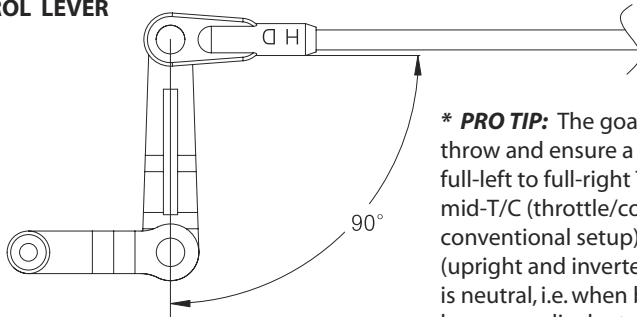

T/R SERVO ARM

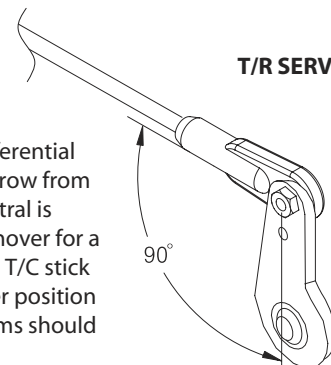

*** PRO TIP:** The goal is to avoid differential throw and ensure a symmetrical throw from full-left to full-right T/R throw. Neutral is mid-T/C (throttle/collective) stick (hover for a conventional setup), or 3/4 and 1/4 T/C stick (upright and inverted hover). Hover position is neutral, i.e. when both control arms should be perpendicular to the pushrod.

8.1 BLADE BALANCE

Equalize Blade CG (center of gravity)

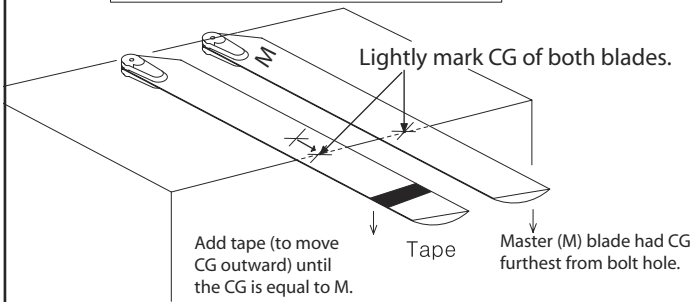

1. First figure out where the CG is for each blade and mark it. The blade with the CG furthest from the bolthole is the master blade - mark it M.
2. Next, add tape to the tip of the other blade until the CG point measures the exact same (from the bolthole) as M. When the CG is the same as M's, mark the CG.

Further tips at: www.audacitymodels.com

*** PRO TIP:** The sharper the edge you balance the blade on, the more precisely you can find the CG. A single edge razor blade works great if you are both patient and precise enough in your work.

Equalize Blade Weight

*** PRO TIP:** Bolt them together with a short length of 4mm Threaded Rod plus a pair of 4mm Flat Washers and 4mm Hex Nuts (not supplied).

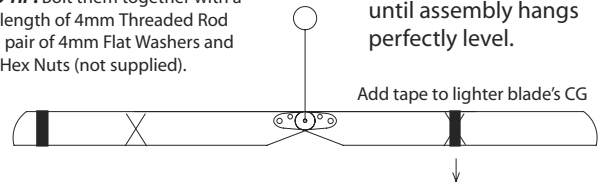

*** NOTE:** Add tape at the CG of light blade until assembly hangs perfectly level.

The next step is static balance - making both blades weigh the same. In the first two steps we made the CG point of both blades exactly the same. Now we must make both blades weigh the same. The only way to add weight to the lighter blade - and not affect the CG - is to add the extra weight on the CG of the lighter blade (that's why you made the mark on both blades). Because manufacturers make an effort to ensure both blades weigh the same, it's likely you won't add tape to M - this technique will work for individual blades from different packages, which don't weigh the same to begin with.

3. Assemble the blades on a table so they're perfect parallel. Perform static balance by adding tape at the CG mark of the lighter of the two blades until they hang level.

8.2 MAIN BLADES

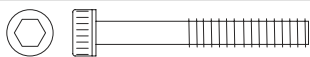

M4x30mm Socket Head Shoulder Bolt (x2)



M4mm Nylon Lock Nuts (x2)

*** VERIFY:** Ensure the leading edge is forward for clockwise main blade rotation.

*** PRO TIP:** The main rotor blades are tight enough when you can move them by hand, yet when you hold the helicopter on its side (with the blades extended), they do not swing loose from their own weight.

*** PRO TIP:** Use a drop of white paint on one blade grip in which to always install the same blade.

M4x30mm Socket Head Shoulder Bolt (x2)

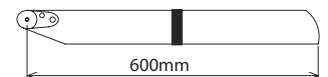
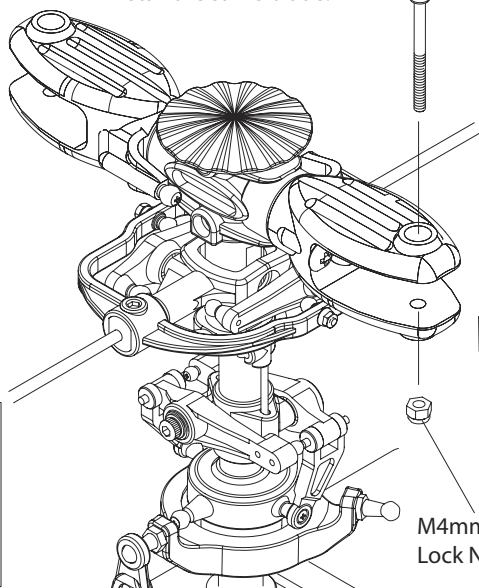

*** PRO TIP:** For wood blades, remove the blade covering material, and use thick cyanoacrylate glue to join the plastic parts.

8.3 CANOPY & WINDSHIELD



Canopy Mount Grommets (x4)



M2x8mm Self-tapping Screws (x6)

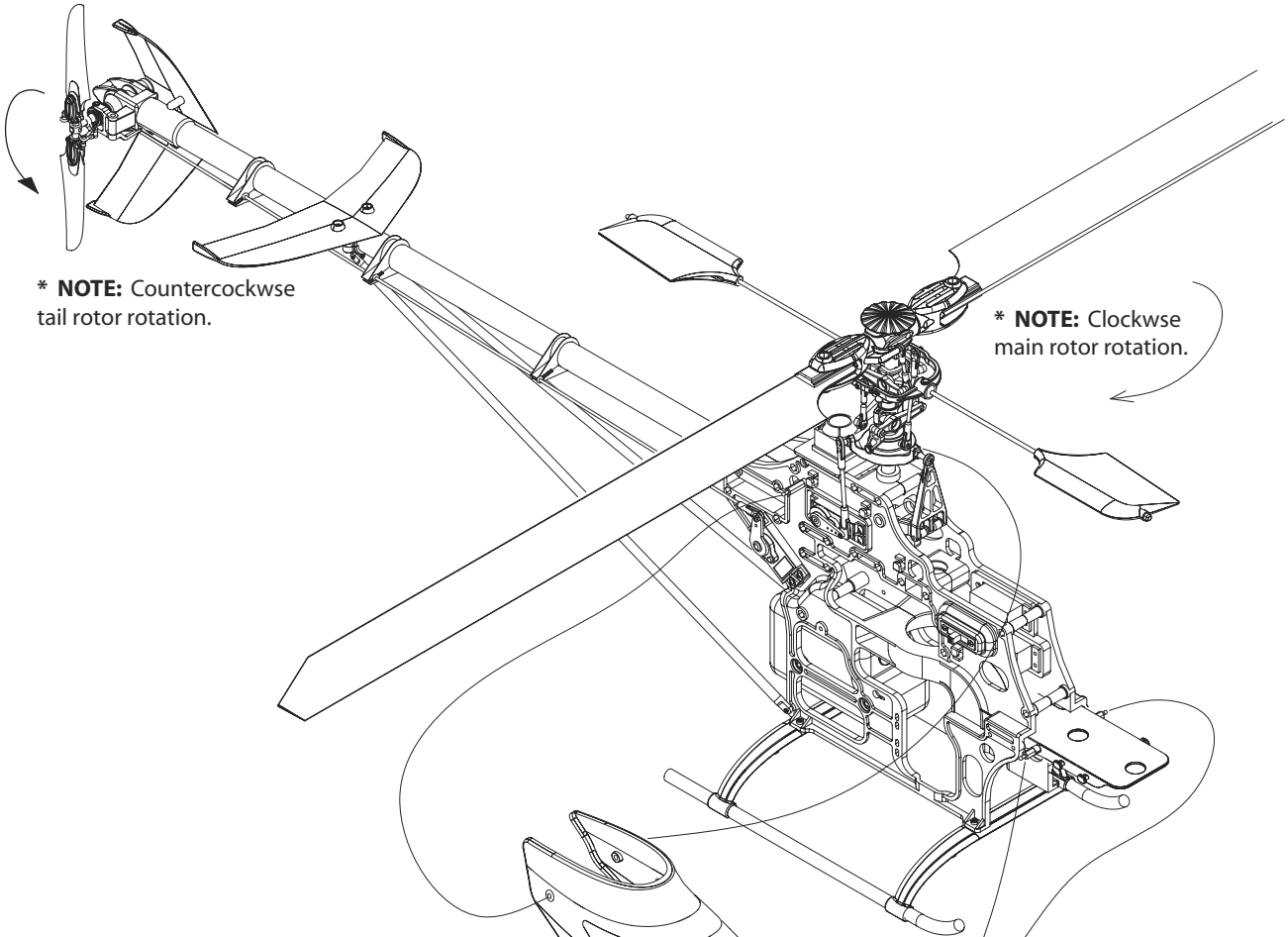

* **NOTE:** Counterclockwise tail rotor rotation.

* **NOTE:** Clockwise main rotor rotation.

Canopy Mount Grommets (x4)

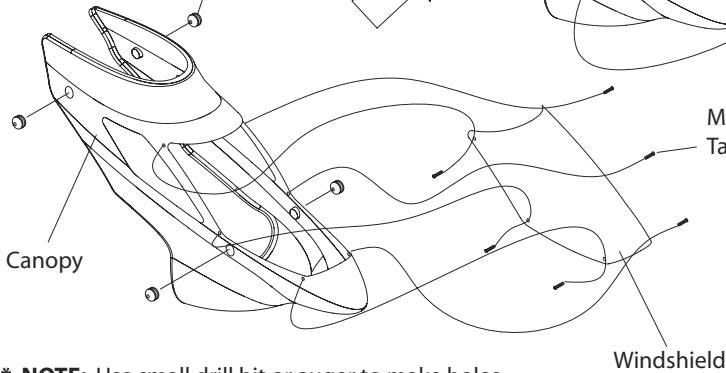

* **NOTE:** Use small drill bit or auger to make holes.

M2x8mm Self Tapping Screws (x6)

* **NOTE:** Cut to the molded trim line using Lexan-type scissors and fasten with self-tapping screws.

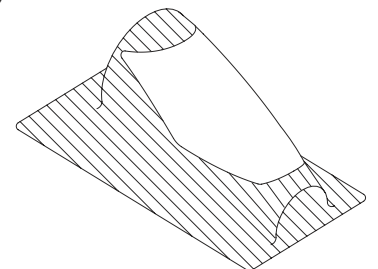

9.0 SET-UP TIPS

This segment of the manual deals with setting up your helicopter in preparation for flight. The set-up includes both mechanical and electronic adjustments to the model.

There are two prevailing schools of thought regarding model helicopter set-up. One sets up a helicopter primarily oriented for upright flight. The other sets up the helicopter for symmetrical flight - this simply means the model is as liable to hover inverted as upright. This flight regimen is also known as extreme aerobatics, or 3D flight.

If you are a beginner, you will have an easier time of learning to fly with a set-up oriented toward upright flight because there is a greater range of pitch to throttle/collective (T/C) stick motion. The T/C stick travels between low and high pitch and hover occur with the T/C stick in the middle of the full range (the model's usually upright).

Extreme performance pilots, on the other hand, demand a set-up which is fully symmetrical, i.e. one in which 0° pitch occurs in the middle of the T/C stick range (instead of hover) and full T/C (max) pitch occurs at *both* ends of the T/C stick range (in both the positive and negative pitch directions). Upright hover thus occurs at $3/4$ T/C stick and inverted hover at $1/4$ T/C stick. This flight regimen is more difficult for the beginner to manage as the range between mid-stick (0°) and maximum (+) pitch is compressed by half. Of course, we assume beginners won't be trying any inverted maneuvers - on purpose that is!

For the **Tiger 50**, the steps are first a symmetrical mechanical set-up followed by any adjustments for the lighter duty needs of the upright regimen (accomplished in the radio). It doesn't get easier than this!

CYCLIC & COLLECTIVE - MECHANICAL SET-UP:

Mechanically it's more important to have CCPM linkages at their respective neutral position in a model set up for symmetrical flight. You can later adjust your model for a predominantly upright flight regimen simply by using the radio system. The converse - setting up mechanically for upright flight and using the radio system to adjust for a symmetrical set-up isn't a sound practice.

The **Tiger 50** helicopter is designed for a full-on switchless-inverted symmetrical set-up from the beginning - there are no compromises for the more rigorous 3D duty! By the way, there's still a switch to throw during flight, but the switch referenced doesn't mean the same thing. The term switchless inverted is a holdover from days when flipping a switch actually reversed the controls!

The steps are the same for all models, regardless of intended duty - be it extreme performance, or sport. Building the linkages per sections 7.1 and 7.2 means all the mechanical linkages will be at the neutral position when the control sticks are in their neutral position. All that is left is to ensure that each servo arm is at its respective neutral positions - 90° to the pushrod. (Figure 1)

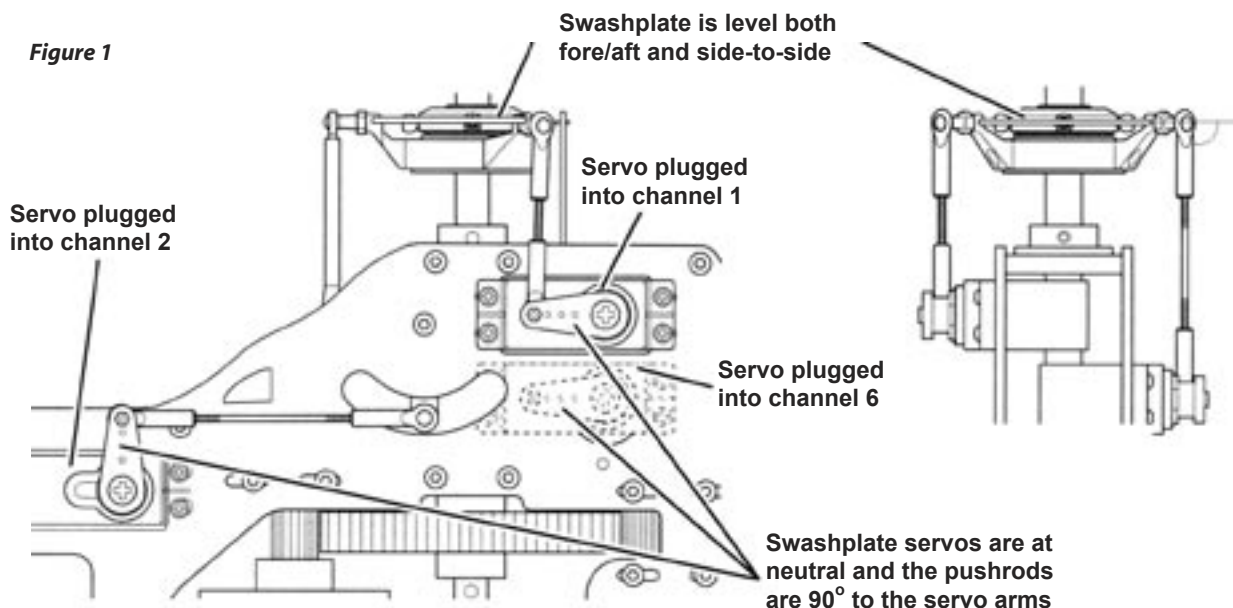

9.1 SET-UP TIPS - CONT.

Look down on the swashplate from above and it is apparent the **Tiger 50** uses a 120° eCCPM system as there are three servos (spaced at 120°) controlling the outer ring of the swashplate. The inner ring, however, is spaced at 90° per usual convention. (Figure 2)

Figure 2

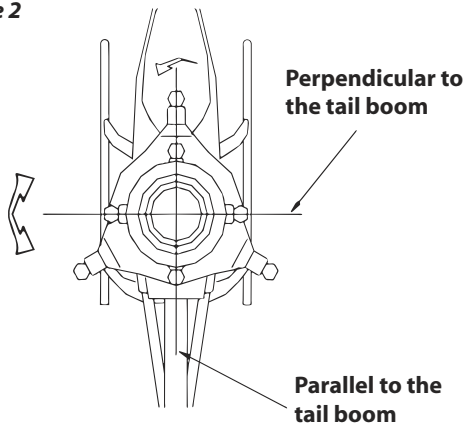

While mechanical methods, or even 4-servo CCPM are very practical methods of inputting controls to the swashplate system (fore/aft cyclic, side-to-side cyclic, plus collective), greater overall system precision and reliability results from the use of 3-servo CCPM. That's largely because mechanical systems have much greater slop, or play in the system - which increases with wear. However, servo failure is more likely than mechanical failure. Thus, inherent in the design of the **Tiger 50** is the elegantly very simple to understand concept of reducing the number of parts in the model to increase reliability (fewer things which can possibly fail). As it turns out, this holds true for the electronics as well - hence, it's easy enough to see where failure of a system with 3 servos is 33% less likely than one with 4.

Mechanical set-up is very important insofar as ensuring the linkages form 90° angles to the servo arms at neutral. Equally important is the idea of mechanical leverage. An even application of leverage to the bearings of the servo occurs when the ball links are installed on the inside face of the three CCPM servo arms at a distance of 20mm from center. (Figure 3)

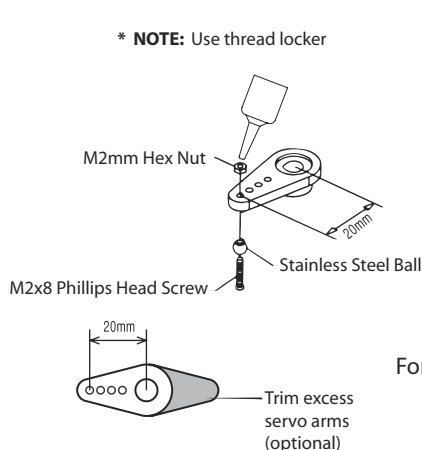

* NOTE: Stainless balls are installed on the underside of the servo arms.

Figure 3

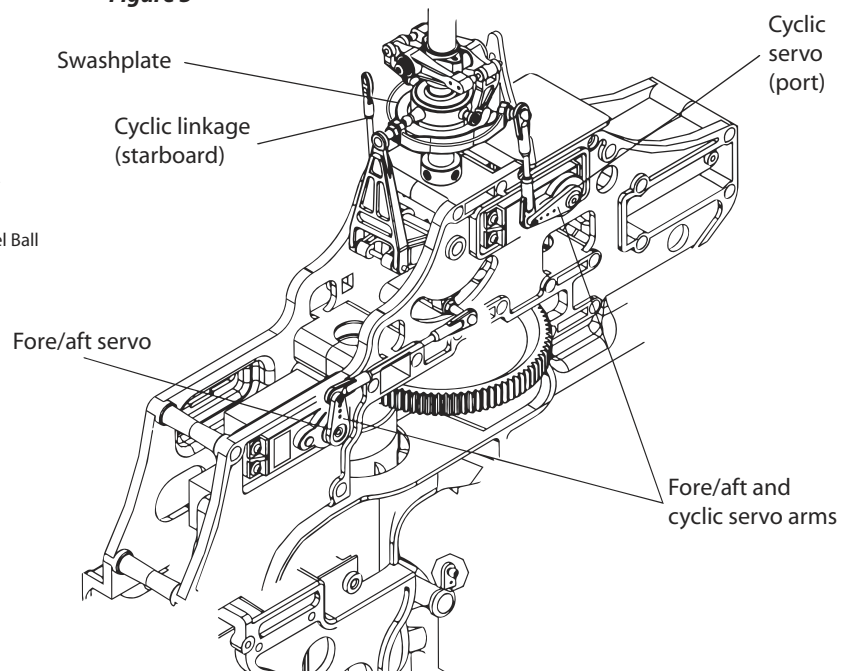

9.2 SET-UP TIPS - CONT.

Verify pushrod lengths for the three CCPM servos. Also verify the HD-mark on each of the plastic ball links *face the screw-head side* of the ball. (Figure 4)

Figure 4

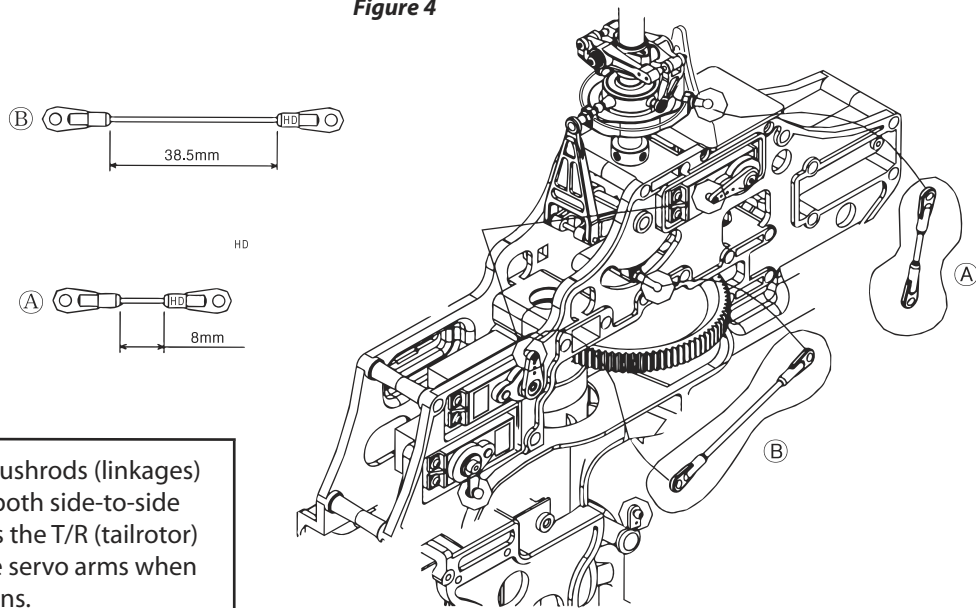

*** NOTE:** Ensure the pushrods (linkages) for the fore/aft servo, both side-to-side cyclic servos, as well as the T/R (tailrotor) pushrod are 90° to the servo arms when at their neutral positions.

*** NOTE:** HD ball-links are *uni-directional*. This means the side of the link that has HD on it must always face the side of the ball which has the screw head.

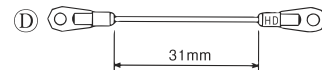
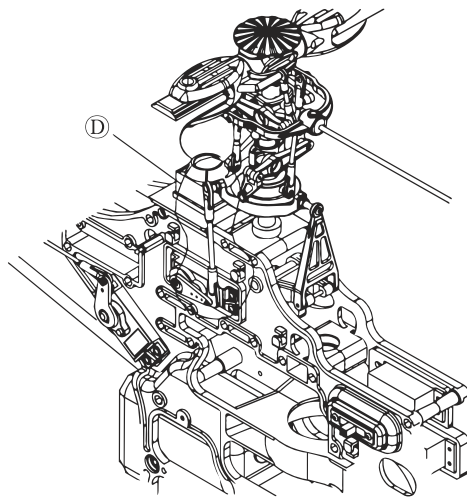

THROTTLE - MECHANICAL SET-UP:

Mechanically setting up the throttle is next. The pushrod length shown for neutral position is approximately the hover throttle opening also, but this dimension is really taken to be mid-point between WOT and idle (not fully closed). This means you set it up with this length, but plan to adjust it after the helicopter has been flown - but *before* making really precise electronic adjustments to the throttle curves. (Figure 5)

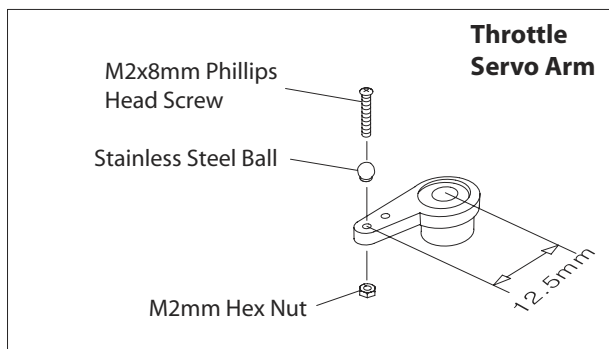
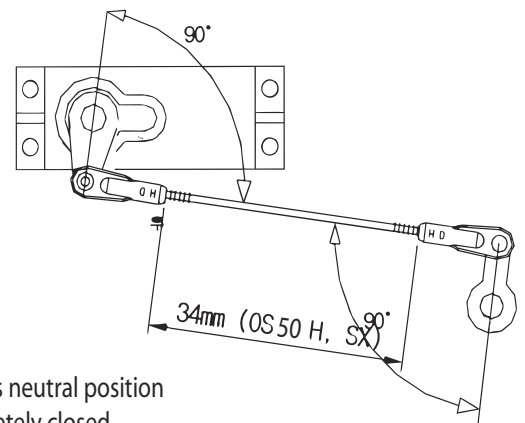

Figure 5



*** NOTE:** Dimensions given for OS Max 50 SX-H at middle of travel - this is neutral position for linkage. This is between WOT and idle - not between WOT and completely closed.

9.3 SET-UP TIPS - CONT.

TAIL ROTOR - MECHANICAL SET-UP:

Mechanically setting up the tail rotor (T/R) is next. The pushrod length shown for the neutral position is for hovering. Again, this is the point at which both tail rotor control arm and tail rotor servo arm make a 90° to the tail boom. We keep harping about this because otherwise instead of symmetrical throw in the linkage, there is differential throw. This means different motion (more to one side than the other) on each side of neutral - it makes flight and adjustments less predictable. Again, as with the throttle linkage, this given length is a starting point - you may need to make slight adjustments after flying the helicopter model. Also, if you are using a heading-hold or heading-lock gyroscope, this dimension is quite likely accurate enough as is and will not need further adjustment. (Figure 6)

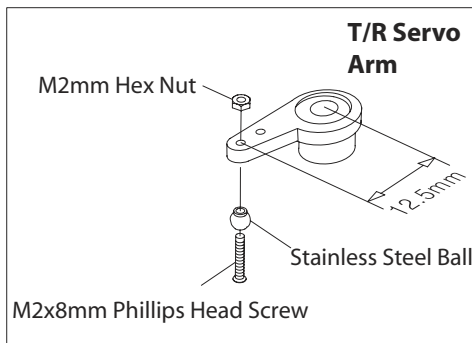
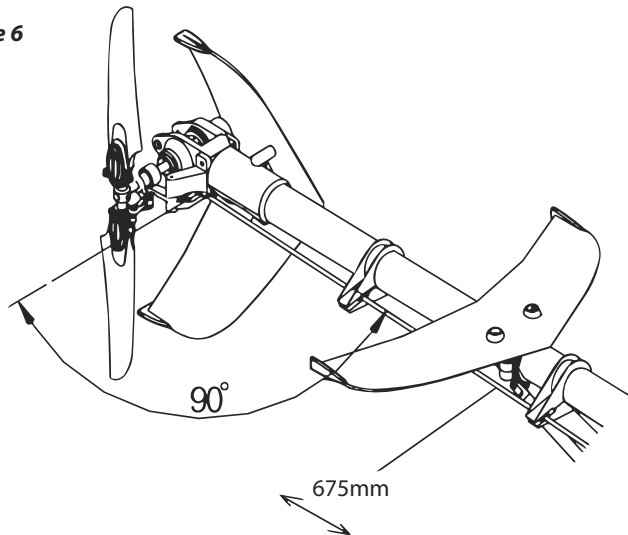

Figure 6



* **NOTE:** Dimensions given are for hover as the neutral position for linkage. This is not with T/R blades at flat or 0° pitch, it's at hover pitch.

ELECTRONIC SET-UP: Introduction

While we like to think the sequence is to always perform an electronic set-up *after* mechanical set-up, in fact, the processes interact to a certain degree. For example, in order to perform the mechanical set-up we need for the servos to be plugged into their respective channels *and* for each servo to be centered, or in its neutral position. We are aided in this process somewhat because we know how long to build each pushrod (for the theoretical center). However, reality intrudes as despite the best efforts of world class engineers and manufacturing processes, the practical effect of the end user installing servos from different manufacturers (and even accessory servo arm manufacturers) means in effect we're really giving you a really close point from which to start making slight tuning adjustments. The more precisely the neutral position for each servo is set, the closer the initial set up will be to the final set-up. In any case, the mechanical and electronic set-up we suggest will be close enough to permit successful test flights from which fine tuning can depart. Next, consult with the radio system's manual and verify the three CCPM servos are plugged into the receiver - something like this. (Figure 7)

Figure 7

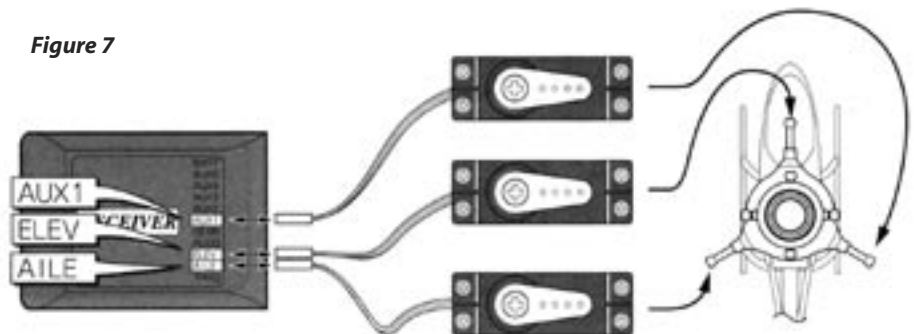

Do the same for the throttle and tail rotor servos - as well as the gyroscope, the switch harness, and the flight pack battery. Once that's done, ensure you've routed the antenna via the antenna tube (3.1) and protected the avionics from vibration (6.4).

9.4 SET-UP TIPS - CONT.

ELECTRONIC SET-UP: Background

We've discussed the two predominant flight set-ups; one oriented for upright flight and other oriented to symmetrical flight. We've also touched on the concept of pitch and throttle curves. Let's elaborate on all this a bit.

As it turns out, the pure symmetrical set-up is fictional since helicopters initiate and end flight with the engine at idle and the rotor blades stopped. Thus, the symmetrical set-ups shares similarity to the upright oriented set-up in what's called the Normal Flight Condition, or Normal Mode. However, first let's review how a helicopter flies before we proceed.

For a helicopter to fly it depends on the lift generated by the rotating main blades. These blades are tilted at an angle, just like a fan or a propeller has an angle and hence, as they spin, they move air. Introduce a positive angle into the blades (leading edge higher than the trailing edge) and they produce lift because they push the air downward while simultaneously *lifting* the helicopter off the ground. The more angle, the faster the helicopter is lifted. But in practice, the practical amount of angle is limited by two things, the horsepower available to spin the main rotor and the angle at which the blades will stall, or stop producing more lift than drag. More on this later.

Similarly, if you introduce a negative angle (or negative pitch as it's more commonly referred to) into the rotor system, the helicopter will push the air upwards forcing the model onto its landing gear. From this simple fact derives the idea that negative pitch combined with a model whose orientation is upside-down and we have the basis for inverted flight. As it turns out, the helicopter doesn't care whether it's right side-up or upside-down!

Examine the airfoil of the main blades and you'll see a strong resemblance to the airfoil of a wing. That's because it is a wing! In fact, it's really not uncommon to refer to helicopters as rotary wing aircraft vs. airplanes known as fixed wing aircraft.

Control of the helicopter is established through

the introduction of additional angles of pitch (both positive and negative) within the overall gross angles we mentioned earlier. Let's look at an example.

Suppose a helicopter uses 5.5° of pitch to hover (the converse holds true as it would use about the same, or -5.5° i.e. *negative* pitch to establish a hover inverted and thus, the convention is introduced of indicating when pitch is negative, otherwise, it's assumed to be positive). Anyway, from a hover, for the helicopter to move forward, the linkages of the rotor system would introduce a little bit more pitch on one side of the rotor disk and remove a bit of pitch from the other. These result in a tilting of the entire rotating disk forward - which would cause the helicopter itself to also tilt forward and thus, move forward. Coming to a stop would entail the reverse, or the tilting the disk aft.

R/C model helicopters use a combination of Bell and Hiller mixing to provide both direct and indirect control over adding and subtracting the small amounts of pitch involved in controlling the rotor disk. It is beyond the scope of this manual to enter into greater technical depth. Let's return to the idea of blade angles, or pitch, as they relate to stalling the blades.

As it turns out, depending on the airfoil, a blade (or a wing for that matter) stalls between 14° and 18° of pitch, or angle of attack (how much higher the leading edge is related to the trailing edge). Because the main rotor may have as much as $10-11^\circ$ of pitch during maneuvers, and because the addition of control inputs will increase the pitch on one side of the rotor disk by as much as $5-6^\circ$ (whilst simultaneously reducing the pitch on the other side, of course - but we're only concerned with where the blade stalls), we need to beware the possibility of stalling part of the main-rotor disk (causing an extended loss of symmetry in lift). The reason for touching on this is related to the extreme power of 50-class engines when coupled with the agile airframe of the **Tiger 50** helicopter which means if you are not careful, you may find yourself on the wrong side of the limits imposed by physics! In short, be aware of the fact that there *are* limits.

9.5 SET-UP TIPS - CONT.

ELECTRONIC SET-UP: Pitch Curves

We suspect that in the course of learning about model helicopters you've heard the term pitch curve or throttle curve bandied about. All that's meant by this is the graphical representation of what happens to a control (servo) when a stick on the transmitter is deflected (moved). Let's see if we can shed some light on this. We'll begin with pitch curves since they're easy to visualize and they relate to orientation (upright or symmetrical set-up).

First some terms and definitions - so that we're all on the same page. We start by assuming you are using a Mode 2 setup in your transmitter. This is Throttle/Collective as well as the Tail Rotor on the left-hand control stick and the fore/aft as well as the side-to-side cyclic controls on the right-hand control stick. Holding the transmitter in both hands and moving the T/C stick towards you will decrease throttle and collective pitch while moving it away, or up, increases T/C pitch. T/C servos are linked electronically. Push the tail rotor stick to the left and the nose of the heli goes to the left - and vice versa. The rotation caused by the T/R is about the axis of the main rotor, i.e. the helicopter will spin around in circles.

The right-hand joystick controls cyclic pitch (which is the adding and subtracting of pitch from the collective pitch). Cyclic pitch tilts the rotor disk and causes changes in direction. Side-to-side, or aileron, cyclic causes rotation about the longitudinal axis (the length - or tail boom axis) so the machine will roll. As you would expect, move the joystick to the right and the machine will roll to the right. In a similarly fashion, the fore/aft directions for the joystick (or control stick) causes the machine to roll about the fore/aft axis. Pushing the joystick away from you dips the nose and a pull towards you raises the nose. Continue to hold the control and the helicopter will rotate in place about that axis (when combined with the well timed and skillful application of collective pitch in both positive and negative directions as well as some T/R to hold position). Did you expect this to be easy? It's not - which is why there are more fixed wing pilots than rotating wing pilots! But you *can* master it.

So what does a pitch curve look like? This is what a collective pitch might look like. (Figure 8)

Figure 8

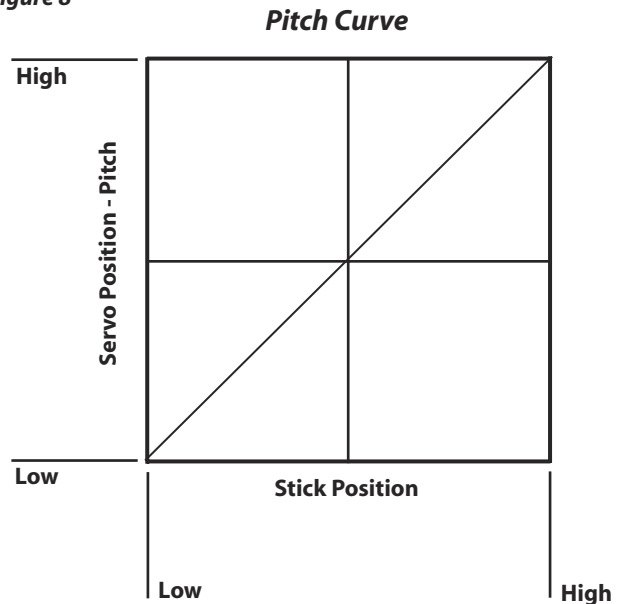

If you're thinking, *That's not a curve, that's a straight line!* You're right as in this case, the pitch curve *is* a straight line. It's an example of the pitch curve for a switchless inverted set-up. Let's put some numbers to the curve to see if it helps.

Below, the pitch curve represents the pitch range from 11° to -11° with mid-stick being 0° . This is the pitch curve of a helicopter, which can perform equally well inverted and right side-up. Either extreme of the joystick represents 11° of deviation from 0° and the upright hover occurs around 3/4-stick while the inverted hover occurs at about 1/4-stick, both with 5.5° pitch. (Figure 9)

Figure 9

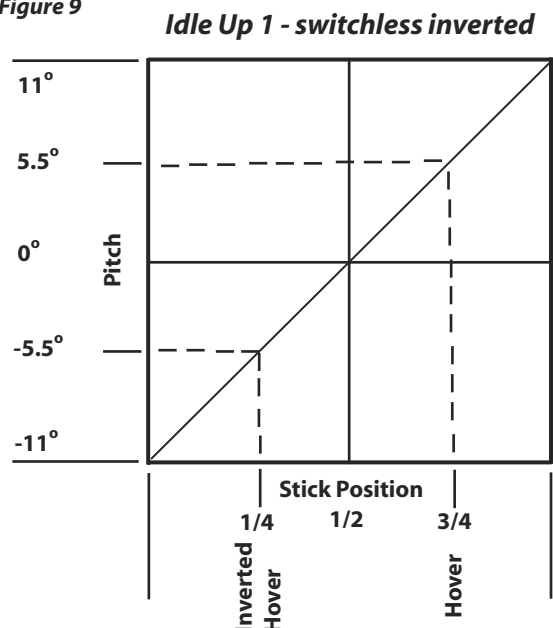

9.6 SET-UP TIPS - CONT.

The shorthand for the pitch curve in Figure 9 would be -11,0,11. It would be understood that we meant $-11^{\circ}, 0^{\circ}, 11^{\circ}$ but the degrees could just as easily be left off. The proper name for the curve in Figure 9 would really be:

Switchless Inverted Pitch Curve, Idle Up 1

The *Switchless Inverted* part you already understand to mean a set-up for symmetrical flight, while *Pitch Curve* is now self-explanatory. The *Idle Up 1* part refers to the flight mode used for most aerobatics. Depending on the brand radio you select, these names may be different ...

Futaba-brand radios may refer to **Idle Up 1**, or **I1** and **JR**-brand radios may refer to **Flight Mode 1**

...but they both mean the very exact same thing!

This brings us to something else. Your radio may, in addition to these flight modes, refer to others like Hold Condition, or Hold Mode, and Normal Condition, or Normal Mode, and even Idle Up 2, or Flight Mode 2. We'll get to these later.

By the way, Futaba uses the Flight Condition while JR uses the word Mode - but we figure they really just do it to confuse us! Don't worry if you hear people referring to Mode this or Mode that but you notice they fly Futaba equipment - it just means they've been hanging around folks who use JR equipment - it's not a sin! Plus, of course, there are other brands too - like Airtronics, Hitec, et al. and each have proprietary terminology you'll need to get the hang of.

Oh, and in case you're wondering, no we're not going to teach you how to program a *specific* radio to the **Tiger 50** in this manual. There are too many radio systems with excellent manuals which explain *exactly* how to set-up a CCPM heli for us to replicate all their work. That, plus the radio models change almost yearly, so anything we put in the manual would soon be obsolete!

Instead, our goal is to give you a grounding in both how and why certain flight modes exist,

combined with some pitch values - which will get your helicopter close to a final set-up - close enough to fly and just make minor trim changes.

As you may suspect, this section was created for folks to whom this is all new. Experienced pilots will just glance at the pitch values we suggest and be on their way without a further glance at this manual!

Since we've discussed the switchless inverted pitch curve Idle Up 1 set-up, let's discuss the Normal Pitch Curve for the same set-up. The Normal Pitch Curve is the one used to start the chopper, carry it to the flight line, and take-off as well as for recovery of the model at the end of a flight. Flying around is done in Idle Up 1 - understand? The goal is for this curve to exactly match the Idle Up 1 curve from mid-stick on up because you don't want the heli to jump up or down when you engage the switch due to a difference in pitch curve profiles. Thus, the top end pitch will be the same; the hover pitch will also be the same (and will still occur at 3/4 stick - exactly as it does for idle Up 1). Similarly, mid-stick will continue to be 0° of pitch. The differences in the pitch curve will only be apparent in the run up to hover. The end result will be a smooth transition between the Normal Mode and the Idle Up 1 flight mode, which can be accomplished from hover pitch on up. At the bottom of the pitch range, there will be about -4° of pitch to enable easy landings even in a stiff breeze (Figure 10)

Figure 10
Normal & Hold - switchless inverted

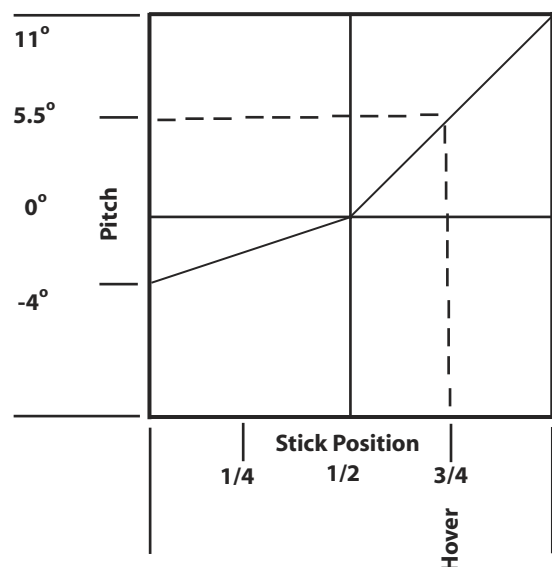

9.7 SET-UP TIPS - CONT.

By the way, if it's not clear, you measure pitch at the blades with a pitch gage while ensuring the flybar is absolutely level. Your hobby dealer will have pitch gages available. With a switchless inverted set-up, there's not often a need for an Idle Up 2 Flight Condition. Some expert pilots who use the condition often mimic Idle Up 1 so as to not have problems if they inadvertently toggle the switch past the Idle Up 1 position. Other expert pilots will have almost the exact same curve loaded but with slight changes to suit perhaps greater wind. We're treading on the territory of professionals. If you don't know *why* you would want an Idle Up 2 (in addition to an Idle Up 1), you likely don't need to worry about it.

This brings us to the Hold Condition. We recommend the Hold Condition pitch curve should look identical to the Normal Curve. The Hold Condition is used for practicing autorotation landings - simulated engine out landings.

The end result is you will have the ability to switch between flight modes, be it Normal, Idle Up 1, (or 2), and Hold without the helicopter doing anything strange. What's more, you can always find the unloaded point on the rotor disk (0°) because it's mid-stick for every single flight condition. This is a tremendous advantage in flight management and will permit the easiest way to master aerobatic flight with the **Tiger 50**.

At this point you may be wondering how do you decide what the top end pitch will be? This is determined by the power of the engine. Some engines being stronger than others can pull 11° of pitch with no problem, others can only pull (without sagging) 10.5° of pitch, etc. It depends on the engine. However, while we can directly *measure* the pitch of the main rotor, we don't have an easy way to measure power output. The easy answer to this is max pitch corresponds to max throttle opening. Usually. The top-level aerobatic pilots however keep a little in reserve at top end pitch so they can add *more* power to make up for the cyclic demands of pitch and power during maneuvers - but that's beyond the scope of this manual. We'll get into all this a bit later when we discuss Throttle Curves.

We've pretty well covered the pitch curves for an experienced pilot who wants to perform any 3D maneuvers within their repertoire.

Upright Orientation: Normal Pitch Curve

Next we'll discuss the minor changes made to the pitch curves for the pilot who is not really interested in extreme aerobatic flight. First up is the Normal Pitch Curve (for upright oriented flight). As you'll see, the curve really doesn't look very different at all, but the values are quite a bit different as the hover point now occurs at mid-stick. In fact, this is a much better set-up for hovering as the sensitivity of the T/C stick is reduced by half! Top end pitch is not changed either. Bottom end pitch is changed to the negative value of the hover pitch. In this case, it's -5.5° (though some pilots may not like the bottom end pitch quite so steep, it does allow greater precision and control for spot landings by adding the ability to drop quite steeply by adding loads of negative pitch).

By the way, have we mentioned just how easy it is to make the changes to the curves? It's done simply by changing the ATV (total amount of servo throw) for each of the three CCPM servos. Of course this is done with the pitch gage installed on the blade so you can interactively make adjustments. It's quite easy and takes only a few minutes to program into the transmitter! (Figure 11)

Figure 11 **Normal & Hold - upright orientation**

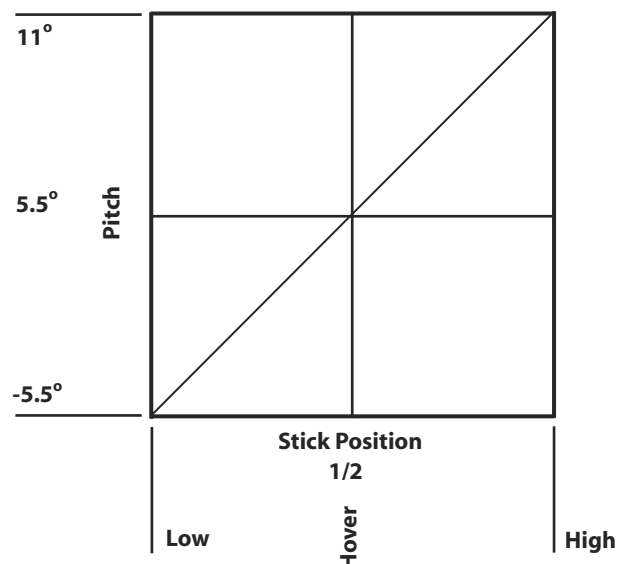

9.8 SET-UP TIPS - CONT.

You may have noticed the T/C stick is no longer symmetrical for the Normal Curve in an upright oriented system because there's 11° of pitch between low pitch and hover and only 5.5° of pitch between hover and high pitch. Earlier we mentioned many pilots don't like the low end of the pitch range setup so sensitive. This is very easy to adjust with the transmitter by decreasing the low-end ATV values of the three CCPM servos.

Below is another Normal Pitch curve - one that many pilots may find more comfortable. However, be aware that in high winds, it may be harder to get the helicopter back down because you'll find a need for more and more negative pitch as the wind speed increases. In fact, in a stiff breeze, a helicopter with only 0° of pitch, seemingly doesn't want to come down! (Figure 12)

Figure 12 **Normal & Hold - upright orientation**

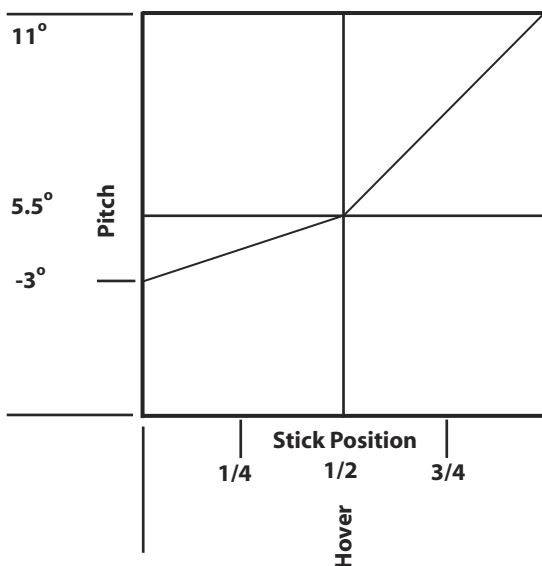

For an upright, or sport, orientation, there's also a need for an Idle Up 1 Pitch Curve because while the helicopter spends most of its time upright, it doesn't spend *all* its entire time upright. This heli will occasionally perform both loops and rolls during which it will be briefly inverted. What does the Idle Up 1 Pitch Curve look like for a machine with a sport orientation? Exactly like the one above! The difference isn't in the pitch curves but in the throttle curves. Why? Because it's critical to always maintain rotor speed, most especially when the helicopter is in the inverted portions of the maneuvers. This leads up to discussing throttle curves.

ELECTRONIC SET-UP: Throttle Curves

As with pitch curves, throttle curves are just the graphical representation of servo position as it relates to stick position. In this case, the stick is the T-part of T/C, or throttle. High stick corresponds to high pitch. The throttle curve for a Normal pitch curve might look like the one below. Notice, how the throttle is closed at low stick and wide open (WOT) at high stick and somewhere in the middle for mid-stick, or hover. (Figure 13)

Figure 13

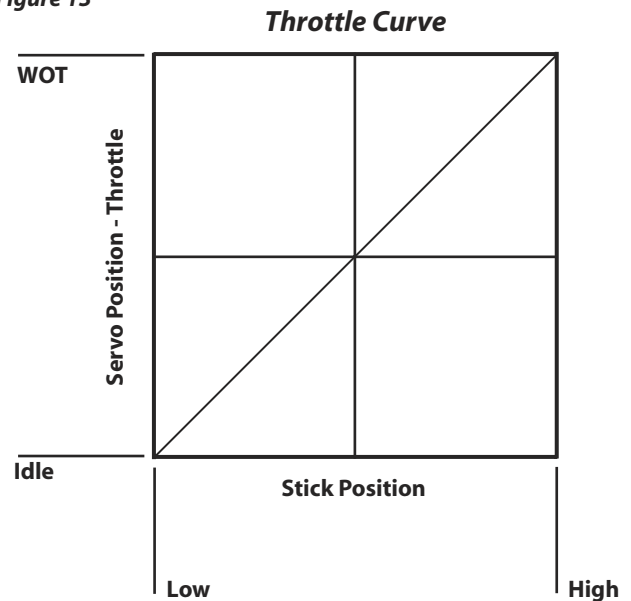

The whole idea of throttle curves is for the throttle to add or subtract power to the main rotor system (by opening or closing the throttle) so as to maintain the RPMs of the main rotor constant. Seems simple enough as increasing main blade pitch means you increase the load, which would slow down the main rotor blades unless we also increased the throttle. Similarly, reducing the load on the main rotor system by reducing the pitch would lessen the load on the engine which is compensated for by closing the throttle the appropriate amount - understand? Hence, the reason why we refer to the throttle collective stick as the T/C stick is because the throttle and the collective pitch move at the same time, or are linked. Usually.

Usually? Yes, the usual relationship means high pitch and high throttle while low pitch is linked to low throttle. But there are times when this isn't the case - during Idle Up and Hold.

9.9 SET-UP TIPS - CONT.

Throttle Curves: Idle Up and Hold Conditions

While the throttle and the collective pitch servos move at the same time, or are linked, for Normal pitch curves, as soon as a helicopter is inverted, the pitch servo moves in the opposite (negative) direction. If the system closed the throttle it would mean disaster, as the rotor speed would decay! Similarly, to practice autorotation, the pilots wishes to disconnect the throttle from the collective stick, in effect setting the engine at idle while permitting the pilot to perform the autorotation maneuver as if the engine had died. Then, if the maneuver isn't coming along well, the pilot flips the hold switch back, the engine roars back to life from idle, and the helicopter can enter normal flight again. Both of these are conditions where the linking of throttle and collective in their usual relationship isn't desired. They are accomplished by throwing a switch.

In the case of Idle Up, the pilot flips the Idle Up switch (which may actually have three positions, Off, Idle Up 1, and Idle Up 2). Engaging this switch tells the radio system to convert both the Normal Pitch curve (when Idle Up switch is Off) to the Idle Up 1 Pitch and the Idle Up 1 throttle curves. The purpose is to keep the rotor speed constant. The actual amount of throttle required is subject to experimentation. If you don't know how to fly inverted, get an experienced pilot to help you - or you'll be in big trouble! Below is what an Idle Up 1 throttle curve might look like for an upright oriented helicopter. (Figure 14)

Figure 14 Throttle Curve

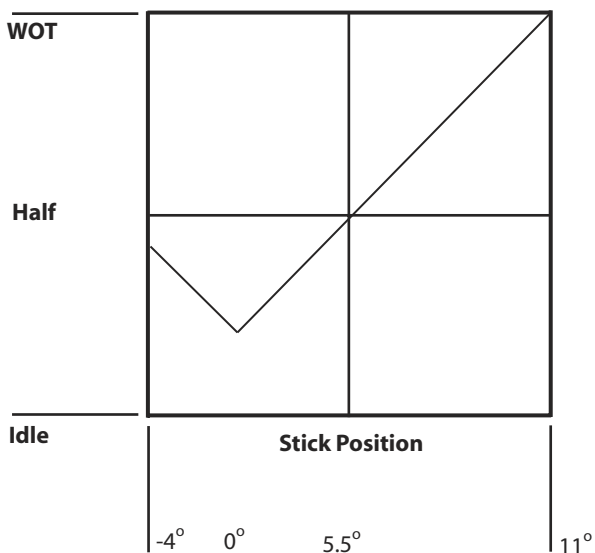

What's immediately apparent is the throttle closes until it hits 0° pitch at which point as the pitch goes negative, the throttle opens up again (some) in an effort to keep the main rotor blade speed constant.

Below is the throttle curve for Idle Up 1 for a full-on extreme performance helicopter. (Figure 15)

Figure 15 V-shape Throttle Curve

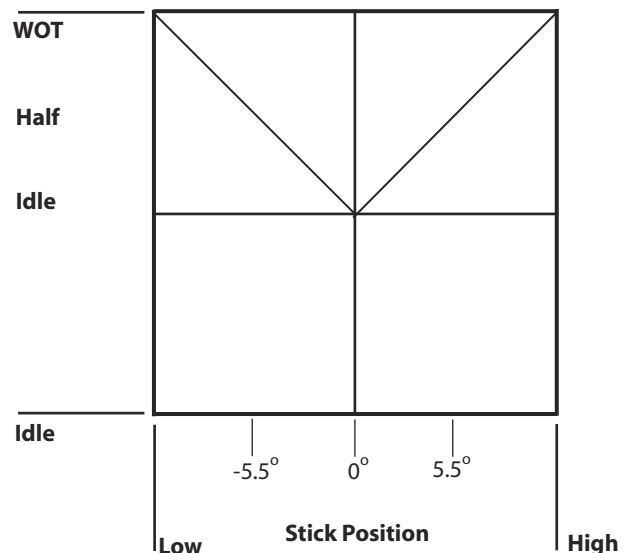

This is what's known as a V-shape throttle curve. It follows the Idle Up 1 pitch curve from Figure 9. You'll note, the low-point for the throttle opening corresponds to about 0° pitch. This is close to an idle setting - but it must be adjusted in flight. The throttle for hover pitch is about the same as for the normal curve. The last curve is the one for Hold. Again, this isn't a curve, it's just a straight line that represents a faster (reliable) engine idle. (Figure 16)

Figure 16 Hold Throttle Curve

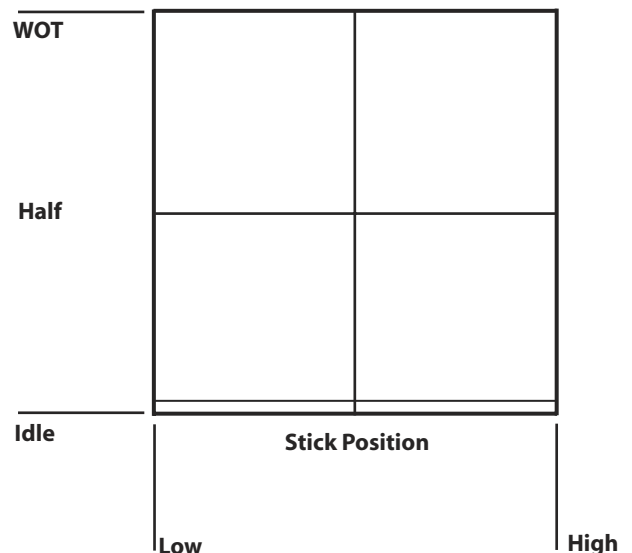

10.0 SET-UP TIPS - CONT.

The amount of throttle in the Hold curve is also determined by experiment. Usually the idle setting is a little bit higher than normal, not a lot, just enough to ensure the engine will *not* die during the descent. That's because if you bail from the maneuver (autorotation practice) by flipping the switch back and the engine is dead, then you are committed to completing the autorotation - or crash! Since the reason you usually bail from a practice autorotation is you've screwed it up somehow, you then find yourself in big trouble. Make certain the engine idles reliably.

In practice, these Pitch and Throttle Curves often don't look like the beautiful straight lines we've used for the manual. Often, to keep main rotor speed from decaying, or from going too fast, the pitch throttle points will not be quite as perfect as those we've shown. It's also worth noting that for all of the example curves demonstrated, we've assumed you've had a radio, which can set 5 points for all the curves. These points are, low-stick, 1/4-stick, mid-stick (or 1/2-stick), 3/4-stick, and full-stick.

For example, many pilots will have a Normal Pitch curve (upright orientation) which looks more like this. (Figure 17)

Figure 12 **Normal Pitch- upright orientation**

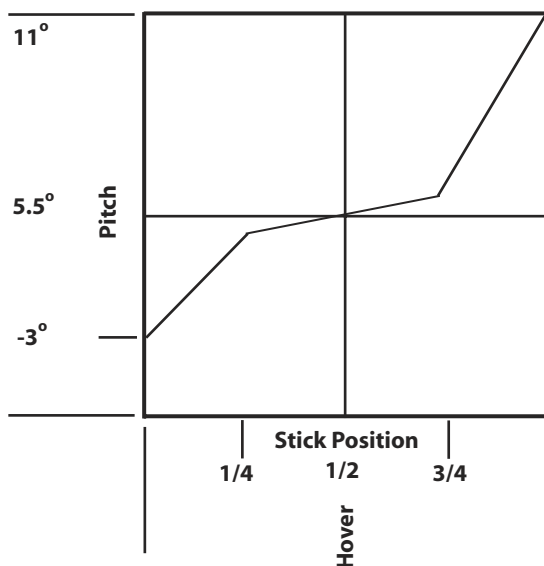

The flattened part of the curve is so collective pitch control for the helicopter isn't quite as sensitive. Similarly, the Normal Throttle Curve for an

upright oriented helicopter will look more like this. (Figure 18)

Figure 18 **Normal Throttle Curve - sport**

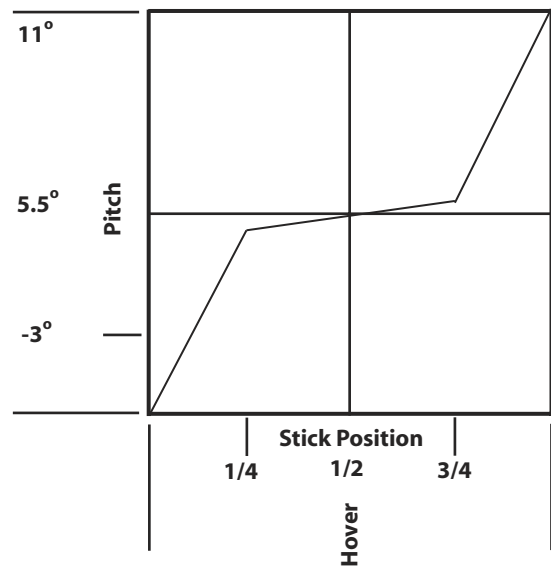

What's happening here is the throttle decreases sharply until the stick is at 3/4-stick then flattens near the hover (mid-stick) position. Again, the curve stays fairly flattish between the 1/4 and 3/4-stick positions which help keeps throttle sensitivity good near hover. From the 1/4-stick position the curve drops steeply again towards an idle setting.

This is what the Idle Up 1 throttle curve might look like for an upright, or sport, oriented helicopter. (Figure 19)

Figure 19 **Idle Up 1 Throttle Curve - sport**

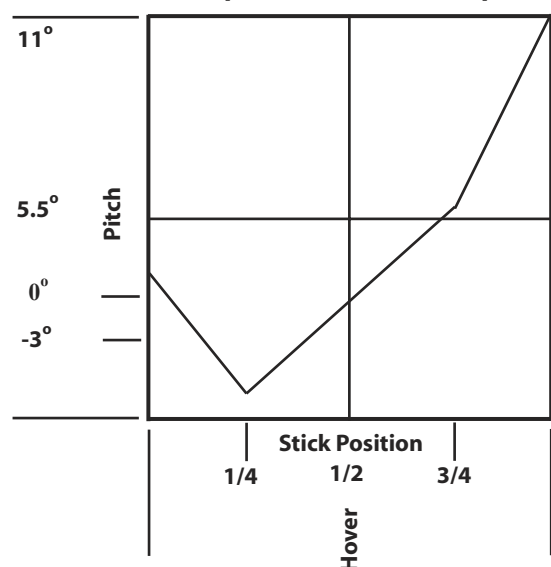

The low point in the curve corresponds to 0°

10.1 SET-UP TIPS - CONT.

of pitch and then the curve climbs as the throttle is opened to account for the fact the main rotor blade system is being loaded again as pitch increases from 0° to -3° of pitch.

The fly in the ointment is the limitation of having only 5 points on these curves. If you have ever wondered why top pilots use radio systems like flagship 9 and 10-channel systems from the likes of Futaba and JR, the reason is these systems have more capabilities - chief amongst them, more points on the curves.

Now let's look at the Idle Up 1 throttle curve for a switchless inverted, or extreme performance, helicopter. (Figure 20)

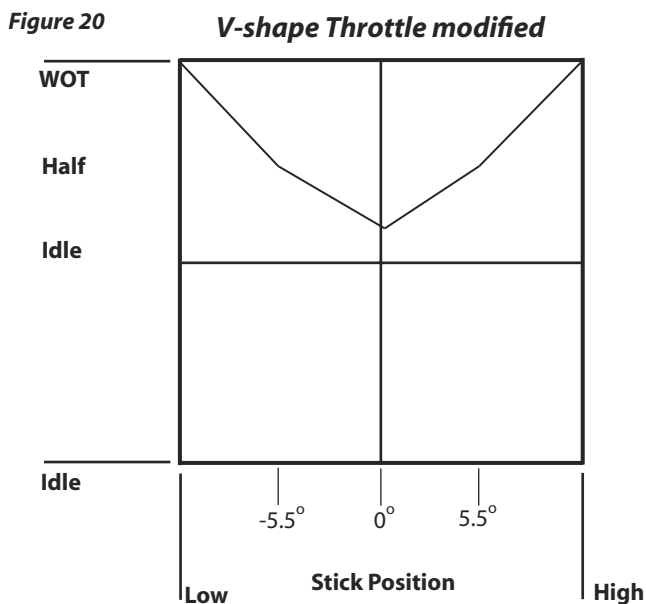

This throttle curve looks much like the V-shape throttle curve from Figure 15, but the main difference is the shallowing out of the curve between hover-throttle and 0° pitch. Also note the throttle doesn't go fully to idle during 0° pitch as the pilot is not going to spend much time with the main rotor unloaded at this point. Instead, this is actually simply a transition point on the way to re-loading the rotor disk as pitch goes negative.

In setting up the throttle curves, you must bear in mind that while we can measure the pitch we set up into the main rotor disk (using a pitch gage), we cannot however, measure the power settings. Hence, the first thing you set after

establishing the neutral point for all the linkages (and ensuring the control and servo arms make perfect 90° angles as they meet) is the desired pitch for 0° -pitch, hover-pitch, and full-pitch stick positions. These, of course, are low-stick, 1/2-stick, and full-stick for an extreme performance oriented helicopter. Then, once each of these stick positions are set, leave the settings alone.

Since we cannot measure power using calipers, a ruler, or any gage we will establish the proper throttle position via flight-testing - empirically! For most pilots, max pitch is the simplest to set because the carburetor is at WOT (wide open throttle) position. Remember, depending on the capabilities of your radio system, you may actually use 95% power at max pitch and keep 5% in reserve for maneuvers (throttle ATV needs to be at 100% - physical WOT). If the engine will not pull the max pitch you established, then the solution is to reduce the pitch curve at that point. If the rotor speed is too high at max pitch, and you already have all the extra throttle (5%) you want in your pocket for maneuvers, then increase the main blade pitch at high stick using pitch ATV.

For the Normal mode, you will use the engine's good-idle speed as the setting for low-stick. Hover power is initially a straight line between the two other positions and is dialed in when actually hovering the machine. If when hovering the rotor speed is too low, then increase the mid-stick position throttle curve. Conversely, if the rotor RPMs are too high, reduce engine power at mid-stick. At this point, as we mentioned earlier, it is important to again verify the hover throttle position has the linkage at 90° to the pushrod. At all costs we desire to keep differential throw to a minimum - with throttle this will promote a linear delivery of the power. All adjustments to the rotor speed are done with throttle curves.

ELECTRONIC SET-UP: Gyroscope

As a rule, piezo crystal gyroscopes have replaced old-technology mechanical spinning gyros. These usually feature heading-hold. When in this mode, turn off the Revolution mix in the radio (all flight modes using heading-hold will have REVO turned off). That's completes initial set-up - now it's time to go to the field!

10.2 SET-UP TIPS - CONT.

FIELD SET-UP: Blade Tracking

You've completed an initial set-up on the workbench; now it's time to make some fine adjustments. The first thing to do is remove the canopy because this will permit easy access to the linkages. This will have a negligible effect on trimming the model, but the prudent modeler may add about 6 oz. of weight to the radio platform to compensate. If the helicopter does not drift too much, proceed to blade tracking before trimming the model. If the machine is in need of so much trim that tracking the blades will be difficult, then perform some trimming first. Hopefully the machine is accurately built and very little, if any, trim will be needed. The procedure is to lift the machine into a low hover (skids a few inches off the ground) and verify the blade tracking. It's great to have an experienced helicopter pilot's help at this stage. Apply tracking tape and verify the blades are in track.

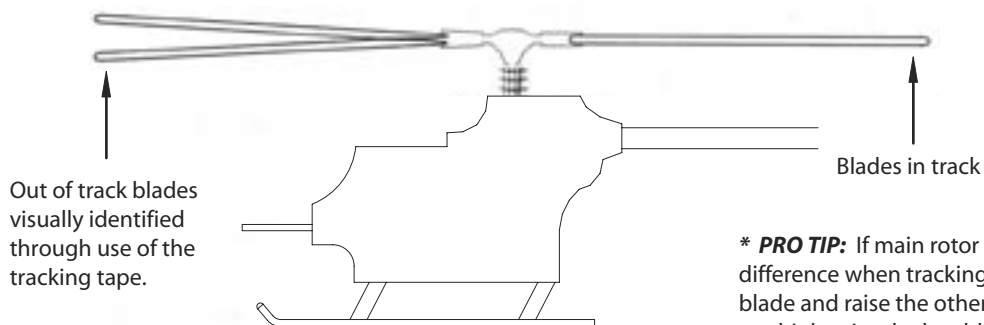

* **PRO TIP:** If main rotor RPM is fine, split the difference when tracking the blades; lower one blade and raise the other - but if the rotor RPM is too high, raise the low blade to match the high blade and vice versa if the RPMs are too low.

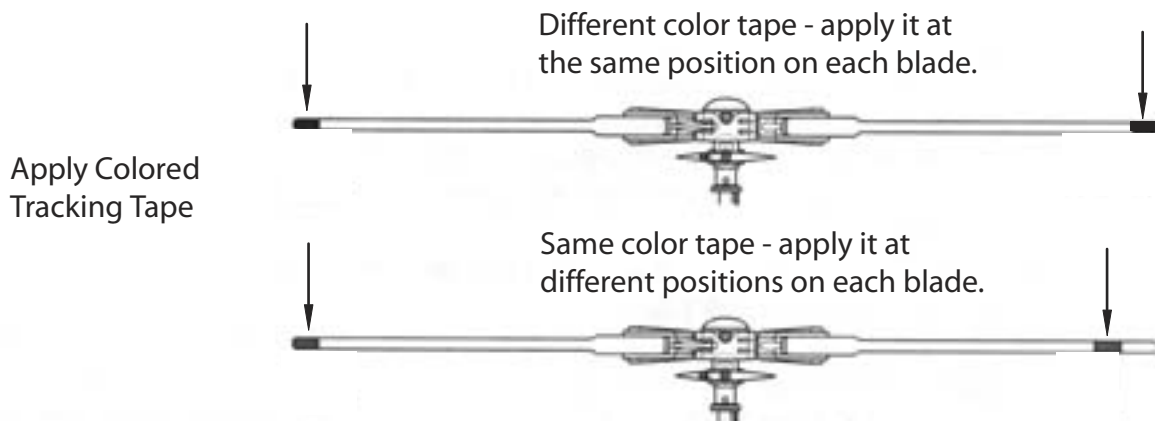

FIELD SET-UP: Trimming & Linkage Adjustment

After tracking the blades, remove the tracking tape, it's time to make trim adjustments. Lift the helicopter into a high hover (skids at eye level) so that ground effect doesn't affect the model. If the model holds position fairly well, or only needs 1 or 2 clicks, you're done. If more than this is needed, make mechanical linkage adjustments to compensate, re-center the trims on the transmitter, and try again. Verify the neutral position for both the throttle and T/R linkages are correct in the hover.

FIELD SET-UP: Dynamic Blade Balance

Remove balance-weight and re-install canopy. Lift model in high hover. If there are some small vibrations, try to dynamically balance the main rotor. Pick a blade and add a wrap or two of tracking tape at the CG of the blade. Lift into a hover and if it's worse, remove the tape and try adding it to the other blade. If it's better but not perfect, add a bit more. This is a trial and error process, which most pilots don't bother with, but time spent here will deliver a much smoother performing helicopter.

A goodie bag of parts, plus some tips to make the Tiger better, are what this addendum is all about.

ADDENDUM v1.9 Parts included: 10) AUD1012 Servo Bosses, 1) AUD0548 Seesaw, and 2) AUD3505 Buttonhead Bolts

1. The new servo bosses AUD1012 included in the goodie bag are slightly shorter so toss the others. Then use plastic-type CA glue to secure them. I prefer that black CA, IC-2000 (rubber-reinforced Tire Glue) from Bob Smith Industries.



AUD1012 Servo Boss

2. Want to make your Tiger flip and tumble faster, i.e. for more aggressive 3D flight? Included in the goodie bag is a seesaw with more holes - part number AUD0548. Review the diagram on page 50 to see where it's installed. Make sure you use the two included AUD3505 button head screws to prevent the seesaw arms binding. If you're learning to hover, or enjoy upright flight with F3C-style flight routines (like loops and rolls), use the outer hole position (as with the original seesaw) and the inner hole to tumble and roll in place (and basically make the Tiger less stable). But be careful because a boom strike is possible when you're too aggressive (which is why we offer stiffer PDR0071 dampers).



AUD0548 Seesaw



AUD3505 M3x8 Buttonhead Screw

3. We forgot to mention in the manual what to do with two little black spacers (4mm dia x 2.8mm), the F3C swashball extensions. Install them under the short balls on the upper ring of the swashplate per the Pro Tip in section 4.1 - these are for sport aerobatic use. For 3D, buy the PDR0069 3D Swashball Kit because it's more of the same (but 4.25mm instead of 2.8mm high). Novices shouldn't install any extensions! Swashball extensions like the F3C and the PDR0069 option are another tool in the arsenal of the pilot seeking to extend the performance envelope via tuning.



F3C Swashball extension



PDR0069 3D Swashball Kit Seesaw

4. We've taken to using epoxy and micro ballons (or JB Weld) to add a reinforcing fillet to the bosses which hold the canopy posts on the radio platform and frames. They seem to break pretty easy so this saves a few bucks!



5. Turns out there is no HD molded on the ball links. Instead, look closely for a lightly molded ring around the lip on one side of the links. This ring-side is slightly larger than the other. Install the link by snapping the ring-side down over the ball.

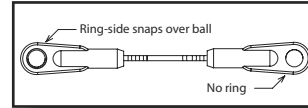

6. 3D pilots (who often fly backward maneuvers) usually prefer a slightly tail heavy setup. But for learning to hover, you want the CG (center of gravity) more forward. We offer AUD0530 (a longer platform), but an inexpensive alternative is to make a plywood platform-extension from 1/8" aircraft plywood. Attach it with screws and zip-tie the battery as far forward as you can thus, shifting the CG further forward.

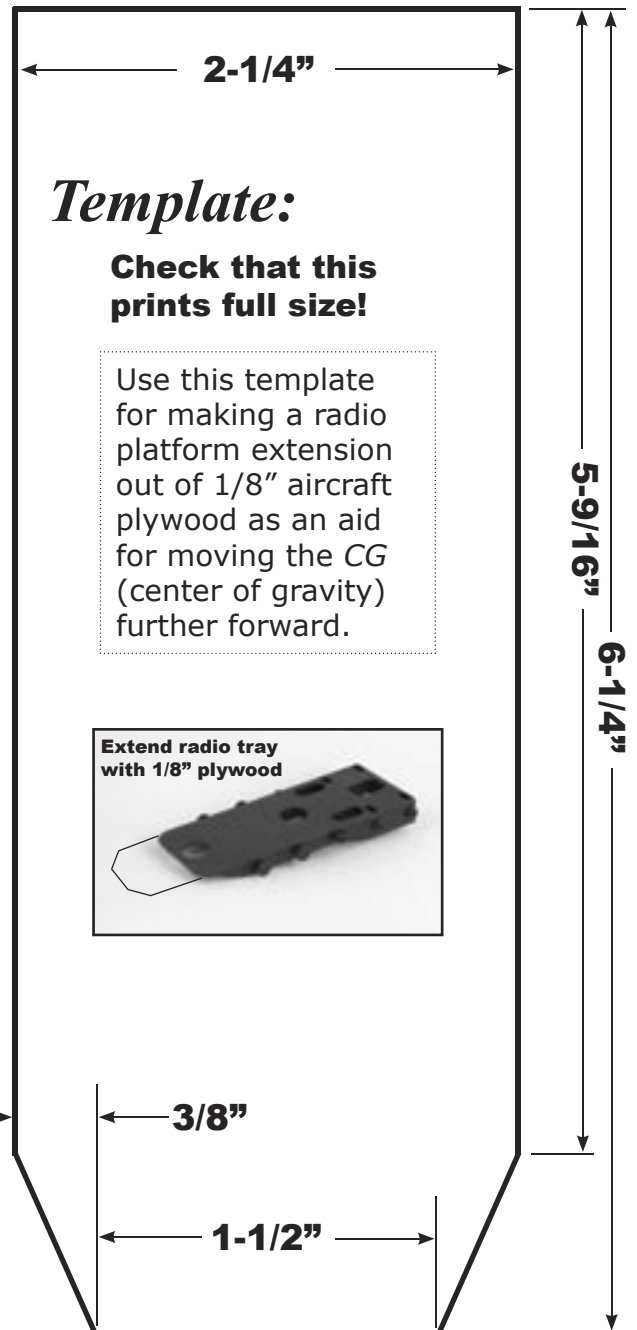

7. Servo arms are an important part of setting up your Tiger. There's a mistake in the manual on pages 26, 27, and 31 where we suggest using 20 mm long servo arms for the three swashplate servos. In fact, the forwardmost servo should operate through a 23 mm long servo arm instead of a 20 mm servo arm. The reason is AUD0027 Elevator Arm reduces throw by 15% to clear the start shaft. Mechanically compensate by using a servo arm that's 15% longer than the arms used on the two aft servos. Hence, a 23mm long servo arm is perfect if you use 20 mm arms for those because $20 \text{ mm} \times 15\% = 3 \text{ mm}$, or $20 \text{ mm} \times 1.15 = 23 \text{ mm}$ thereby resolving the issue quite elegantly. We're partial to the HD servo arms manufactured by Du-Bro, their parts #670 for Futaba, #671 for JR, and #672 for Hitec brand servos. Also, instead of a 12.5 mm servo arm for the tail rotor servo we're using a longer arm (15-18 mm) instead.

8. Under hard use, thread locker securing the pinion gear of the AUD0526 Clutch Bell Assembly to the AUD3077 10x19x7 bearing can work its way loose. If you're hearing a ringing sound (kind of like a bell) the pinion may have worked its way loose. The fix is to clean the old thread locker off with acetone and re-assemble with thick CA or JB Weld. The real trick to making it bulletproof though is to use thick CA or JB Weld on it while it's new! Remove the front landing gear bolts and drop the engine. Some have reported they're placing a pair of needle-nose pliers on top of the clutch bell and giving it a tap with a hammer to pop it loose, but because some have also damaged the frames where it holds the bearing, we think it's best to just split the frame! We get away with just removing the frame bolts forward of the Tail Drive Pinion Assembly and flex the frames open (make sure you remove the M3x12mm that's inside the curve of the fan shroud too). In fact, you may not even have to remove servos because there's usually enough slack in the wiring. Next, clean the thread locker off with acetone or laquer thinner (the thread locker dissolves very easily) and use either thick CA or JB Weld to re-bond the pinion into the bearing (instead of thread locker as detailed in step 1.1). However, as with thread locker, be especially careful not to get CA into the bearing because it'll lock it up tighter than a tick on a hound dog . . . you've been warned!

9. Disassemble the thrust bearings located inside the main rotor blade grips and grease them. This will maximize service life. We have used many types of grease and don't think which kind matters in the least regardless of whether it's wheel bearing grease, white lithium grease, or whatever you have on hand! This is an easy job, but please refer to the drawing for proper thrust bearing re-assembly as detailed in the manual's exploded views (refer to 11.3 Main Rotor Head & Seesaw). There's really only one thing that might bite you on the rear. There are two grooved washers in each thrust bearing pack, and getting them backwards will make blade tracking inconsistent since these washers differ slightly in the ID. Just make sure the grooved washer with the larger ID is installed on the hub-side while the one with the smaller ID is installed toward the nut-side. Finally, while you're at it, put just a smear of grease on the dampers (where the spindle shaft rides) so that they don't bind.

10. There's a mistake in the manual affecting steps 3.3 and 3.5 because these bolts are reversed. The correct bolts to mount the engine to the engine mount (as detailed in step 3.3) are the 3x12 mm shown in step 3.5. The longer 3x15 mm bolts (from step 3.3) should instead be used in step 3.5 for securing the engine mount (with aluminum cap washers) to the side frames.

11. Turns out the note about not using thread locker on the crankshaft nut (step 3.3) isn't the last word. We now think it's best to use blue thread locker to secure the nut. Also, if you dial-indicate the AUD0037 Clutch Hub (to minimize vibration), then PDR0090 Equalizing Nut (used in the wings of Boeing jets) is the Cat's Meow to keep the runout from changing as you tighten the engine nut because its ball-and-socket design prevents it from pulling the hub off center!



PDR0090 Equalizing Nut

12. Complaints of the tail boom working loose have two usual sources - using a screwdriver-handle type Allen to tighten the four M3x38 mm aft frame bolts vs. an L-shaped or T-handle Allen-wrench (to really tighten the suckers), or forgetting to tighten the M3x4 set screws located on each side frame (as detailed in step 5.7). Here are a couple of tips; first, while some advocate a wrap of electrical tape on the boom before plugging it in, we DO NOT think this is necessary. If you feel you must, you can tighten the fit this way instead; remove the four aft frame bolts and pass a thin Zona-type saw blade between the crack formed where they join - this removes a few thousandths of material. Better still, if the frames haven't been assembled yet (or you're willing to disassemble them), lightly pass a sanding block on the aft part of the frames before joining. Second, substitute a couple of M3x10 Allen Head bolts for the supplied set screws so that you can use the same 2.5 mm Allen driver everywhere - these don't round out as easily! Also, because it's not unusual for these safety set screws to actually punch through the boom (which certainly keeps it from working loose), we first fly the heli a time or two (because the belt stretches a little) and then we secure these safety set screws!

13. On 9.0 Set Up Tips, there's a mistake as the two aft servos are reversed. The starboard (right) aft servo should actually be plugged into channel 1 and the port (left) aft servo should instead be plugged into channel 6. The same issue pops up with different brands of equipment as per step 9.3 where channel numbers are referred to as Aux 1, ELEV, and AILE - please refer to your radio equipment's manual for specifics.

14. AH-xxxx and PRO-xxxx part numbers are superseded by AUD-xxxx and PDR-xxxx - numbers don't change.

15. We've been fortunate that some of the best 3D pilots in the world have chosen to use a Tiger 50 as a "beater" for practicing the presentation of their 3D routines. As a direct consequence (because they fly their Tiger 50 harder than mere mortals) their ideas may lead to improvements for the rest of us. The tip that follows is one that we call the "Henry Caldwell Tail Pitch Control Lever Modification".



This mod involves AUD0010 Tail Pitch Control Lever, and requires an X-Acto with a #11 blade, a drill, the appropriate drill bit and 3 mm tap, as well as PDR-0079 3D Guide Pins. These can increase the service life of the tail pitch control lever under grueling abuse imposed by aggressive 3D pilots.



PDR0079 3D Guide Pins

- Step 1** - Remove AUD0010 Tail Pitch Control Lever from the Tail Gear Case Assembly by using a drift to drive out the tail lever bushing - a makeshift drift can be an Allen driver.
- Step 2** - Use the X-Acto to slice off the two plastic nubs which fit the grooves to drive AUD0014 Tail Slide Ring.
- Step 3** - Drill and tap for 3 mm. This is easy because there is a round molded recess directly opposite (on each side) from where the pins were. Just be careful to center the drill bit beforehand and go for it. If you screw up, it's not the end of the World, a replacement AUD0010 is inexpensive.
- Step 4** - Use a drop of plastic CA glue as a thread locker and an Allen driver, screw in the PDR0079 3D Guide Pins.
- Step 5** - That's it! Reinstall the Tail Pitch Control Lever.

Special thanks to: Henry Caldwell for coming up with the idea, Marcus Kim for letting his Tiger 50 be the guinea pig, Eric Reinhart for the tools to accomplish this, and most especially Lee O'Dell for generously donating the guide pins off his Freya for the experiment. The idea was prototyped at Blacksheep, SC over the 2005 Independence Day Holiday and a mere 5 weeks later we had approved the drawings, manufactured the guide pins and were shipping! This little modification can really help maintain precision longer!

16. Assembling the AUD2003 Ball Link Ends to the AUD1521 Tail Rotor Pushrod becomes a lot easier if you first use a 5/64 drill bit (.078") and drill out the slightly undersized holes before threading them onto the pushrod.

17. We've had reports of blades occasionally going out of track and have learned it's related to excessive play in one of the Seesaw Arms. Check for excess play before flying your model because the resulting flutter can easily be strong enough to lead to a Spindle Shaft bending. Fortunately, the shaft is a sacrificial part and hence, is cheap and easy to replace. The cause is usually either the screw securing the Seesaw Arm on the shaft has backed out slightly, or there's a ganging of tolerances which has resulted in a loose fit on one of the arms. Checking for either condition is actually pretty easy. First, grasp the Seesaw Arm between your thumb and forefinger and give it a side-to-side wiggle. Next, rotate the head around and check the other Seesaw Arm the same way. If you've experienced blades going out of track, then dollars to donuts there's more play in one Seesaw Arm vs. the other!

You may be asking yourself, "What's ganging of tolerances?" Simply this . . . it's surely no surprise that two bearings with the same part number can actually vary slightly in size, right? I.e. measure them using instruments of sufficient precision and you'll almost always discover that one can be slightly thinner than the other. Similarly, the ID and the OD can vary slightly as well. The same holds true for the shaft - such that it might be slightly longer than others in the same parts bin. Ditto with the seesaw arm itself, but nonetheless, these differences are within the +/- tolerances of the design. Then during assembly; thinner bearings, maybe a seesaw arm with a thinner ring gap, or perhaps a longer shaft, when assembled result in slightly too much play in one of the seesaw arms. It doesn't happen often but occasionally parts (each in proper tolerance) when combined may result in an assembly that's out of tolerance - in this case too lose!

First, just try tightening the bolt. Be careful though since this bolt threads into the plastic seesaw. Fortunately, if it's stripped, all's not lost since plastic-type CA used as thread locker will have you back in business because you can pretty much restore the threads using it. If the damage is too bad, happily, seesaws are inexpensive so it's not that big a deal.

If it's not loose, then back the bolt out and look to see if the shaft itself (the one the bearings ride on) isn't just a hair too long (you'll see it sticking out past the inner race of the outer bearing of the seesaw arm - it's pretty easy to discern). If this is the case, then file a few thousandths (or however much is needed to make for a perfect fit) off the end of the shaft.

That's how you remove the extra play and the process is called "blue printing". Top pilots blue print every assembly of a machine. Most of us aren't top pilots, but blue printing an assembly is a simple, easy, and free modification. Best of all, it may result in a tangibly better handling helicopter plus it's fun to do - after all, it's called modeling for a reason! While you're at it, check the mixing arms for excess play and blue print them to perfection also!

18. A member of the Audacious Crew came up with an idea for making the Tiger 50 fly better and it really works! It's called the "**Kevin Garver Positive Delta Modification**" and it makes for a real improvement in the flying characteristics of the Tiger 50 . . . and it doesn't cost a thin dime! His idea led to this recommendation for flipping the main rotor blade grips over so the main rotor blades are controlled from the leading edge vs. from the trailing edge (resulting in positive delta vs. negative delta). The ensuing aerodynamic forces work to provide more precise collective and cyclic control and best of all, it's both easy to accomplish . . . and free!

The goal is to invert, or mirror image, everything north of the Swashplate. These include the Mixing Base/Mixing Arms, the Seesaw/Seesaw Arms, and the Control Lever Assembly as well as the Main Blade Grips. It's easy, here's how . . .

Step 1 - DISASSEMBLY - use ball link pliers and remove the links (to include the Washout Link) leading from the Swashplate up to the Main Blade Grips. Then remove a Flybar Paddle, loosen the set screws on the Control Lever Assembly, and slide the Flybar out as well. Take the Seesaw Arms off the Seesaw followed by the two screws holding the Seesaw onto the aluminum Center Hub Assembly to remove the Seesaw itself. Next, remove the Jesus Bolt and lift the Head Assembly off the Main Shaft. Finally, lift the Washout Base/Mixing Arms off the Main Shaft.

Reversed Main Blade Grips

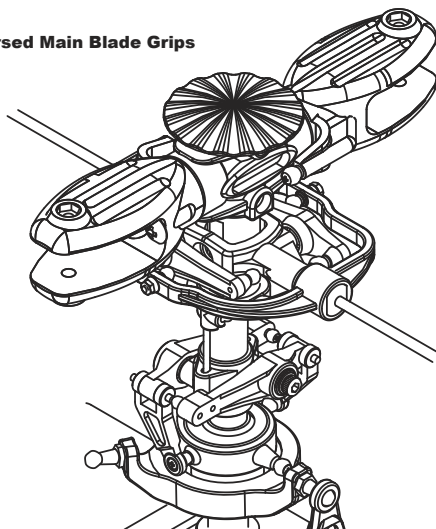

Step 2 - MODIFICATION - For the full collective pitch range (-11/+11 degrees) you must cut about 1/8" from the bottom of the Washout Base (if you're not doing full inverted climb outs, don't bother because you get about -8 degrees without modifying the mixing base - enough for a moderate inverted climb out). I use a Dremel tool with a cutoff disk but because the inner liner of the Washout Base is made of steel it's helpful to occasionally dip the Mixing Base in a bowl of water to keep the steel sleeve from getting too hot and melting the plastic. Alternatively, get someone to hold a wet sponge above the Washout Base and dribble water on the job for cooling (as you cut it). Also, use the Dremel and cutoff disk to trim enough (about 1/8") off the rotor blade bolts to keep them from gouging your palm when you use your hand as a rotor blade brake - you've been warned!

Step 3 - RE-ASSEMBLY - Refer to the drawing. First replace the Seesaw - remember to invert it. Reinstall the Seesaw Arms, then slip the Control Lever Assembly in place and ease the Flybar through it and the Seesaw. This has been done correctly when the Set Screws which secure the Flybar are tightened from the bottom vs. from the top. Now replace the second Flybar Paddle and re-align everything. Then, re-install the Mixing Arms onto the Washout Base and slip this over the Main Shaft - but ensure the side which you cut off faces upwards and the Washout Arms are reversed. Snap the Washout Links onto the long balls on the upper star of the Swashplate. Next, re-install the head assembly and the Jesus Bolt - and please remember to tighten it securely. Trust me when I say it's a sick feeling to watch the rotor disk go sailing off pretty as you please while the Tiger 50 imitates a costly Lawn Dart - and don't ask me how I know, but you've been warned - sob! Now remove one of the M4 Nylon Lock Nuts from the Spindle Shaft and slide the grips apart enough to permit you to rotate them 180 degrees (flip them over in other words) and re-tighten the M4 Nylon Lock Nut. Finally, re-install the linkage rods.

Step 4 - PROGRAMMING - Next, let's reverse the pitch direction - do this in the Swashplate Menu of the transmitter. It's where you have values for Elevator, Aileron, and Pitch. All you do is reverse the value for Pitch. For example, if the value is +55, change it to -55 . . . or from -60 to +60 and the Swashplate will now move down for positive pitch instead of moving upward - and vice versa! You're done!

This is the new "official" way we recommend assembly of the main blade grip control. The only downside to this little modification is the set screws securing the flybar are reached from below and similarly, the bolts securing the main rotor blades install from the bottom as well - a small price to pay!

19. Installing the 3D paddles is simplicity itself, but you must ensure they are properly installed. Make sure none of the threads on the flybar are exposed, i.e. that they're fully covered by the body of the paddles (or the flybar can break where the threads start). Just make a mark 1" from the end of the flybar, then screw the paddles on until the inside edge of the paddle meets the mark. Also, some 3D-pilots like to experiment and try to improve the flight characteristics when using these paddles - it's easy. First, slice 1/8" off the leading edge. Next, using a sanding block, simply re-profile the edge back to an aerodynamic shape. Finally, check to ensure they still weigh the same - that's it!

20. The inevitable will occur. Yes, despite your best efforts (perhaps even due to your best efforts), the time will come when your Tiger 50 meets *terra firma* at a rapid rate and what results is a smokin' hole in the ground! Inevitably this greatly amuses the peanut gallery (while you'll be shaking your head in dismay). If (when the momentous occasion occurs), the damage includes the AUD0013 Tail Pitch Plate (this piece supports the two AUD0012 Tail Pitch Links and threads onto the AUD1005 Tail Slide Ring Sleeve), then remember this - the assembly doesn't use the usual right-hand threads . . . it uses **left-hand threads** - you've been warned!

10.7 ADDENDUM

21. I've been asked a few times about lubing bearings and other points of friction on the Tiger 50. First, remember the goal of lubrication is to reduce friction and the resulting accelerated wear due to the rubbing together of parts. We do this with lubricant. This, naturally enough, raises the question of what to use? While I happen to think that even spitting on it is better than nothing, I also suspect some may want a recommendation other than that. I don't care for WD-40 for this application (though it's better than nothing also), and 3-in-1 (or any light sewing machine oil) is decent but attracts dirt - which is bad! I prefer a synthetic high tech lube like Tri-Flow with Teflon. This brings us to where and how often the lubrication should be applied.

To lube the little bearings contained within the tail rotor blade grips, I place a few drops on the hub side of each tail rotor grip (right on the shaft itself, actually). Then rotational forces will ensure the oil flows through the bearings! For good measure, I also lube where the tail slide ring sleeve rides on the tail output shaft. While I'm at it, I also put a couple of drops right where the swashplate rides on the main shaft. Ditto for the washout base also. That's because these both ride up and down on the main shaft with pitch changes. I also put a few drops at the main rotor blade grips (the same as for the tail rotor grips, i.e. right on the shaft and let rotation distribute the oil throughout the bearing). Finally, I place a drop or two at each main shaft bearing, the start shaft bearings, and the tail output shaft bearings also. I lube these places before flying begins for the day.

However, with respect to lubing the bearings in the main rotor blade grips, I rather suspect this may also be serving to wash some of the grease out of the thrust bearings. But unfortunately, there doesn't seem to be an easy answer for this issue since oil seems best for ball bearings and grease for thrust bearings. Hence, I re-lube the thrust bearings every time the spindle shaft is replaced, or after every case or two of fuel - presuming I have't had the head/grips apart due to a crash repair!

Are you're wondering how well rotational forces work? Following the first flight after lubing the bearings in the grips using this method, I have to wipe excess lube off the roots of the main rotor blades as well as the tail rotor blades (to remove the lube that was slung through the bearings).

Anyway, that's how I do it . . . and it's not just for my Tiger, but for all my helicopters! By the way, one reason I lube so frequently is because I also happen to be meticulous about keeping my helicopters clean. To make this job easier, I spray them down with denatured alcohol once I get back to the workshop. Next, I use a jet of high pressure air (from my air compressor) to blast things nice and clean! Finally, I touch up by wiping with a diaper (these work great for rags) whilst checking for anything wearing or broken (which may have escaped my attention at the field). Since it seems to me I may very well be washing away some lube along with any oil and dirt on the model, I figure the best thing to do is just re-lube these points before the start of flying each day.

22. Four large (about an inch in diameter) black plastic washers (included with the model) are shims for the main rotor blades. That's because the main rotor blade grips are designed to accept either the stock 12 mm thick blade root, or accessory 14 mm thick blade roots. The shim washers are designed to be fit on each side of each main rotor blade (they're only 1 mm thick) before being inserted into the grips and while they're something of a tight fit, they do fit! Some folks advocate permanently gluing them to the blade roots using CA-type glue. While there's nothing wrong with this, I'd recommend using a tiny drop of CA instead so you can salvage them in the event you break the blades. Then all you'll have to do is slip the a #11 X-Acto blade under the edge of the washer and pop it loose. Lynn says I shouldn't be so cheap . . . I just think I'm being thrifty!

23. We've had some issues with the threads in the body of the AUD0001 Hex Start Adapter not being fully cut. Before final assembly using thread locker, make sure the threads are actually cleanly cut by first running the set screw all the way into the body until you see it penetrate into the center (which is how it secures the adapter to the flat of the start shaft). If the threads aren't clean, then just run a tap through it to finish cleaning them up. Finally, remember to use plenty of thread locker so the hex start adapter doesn't come loose . . . which as we all know, Murphy's Law dictates will always happens at the field while you're showing off your new pride and joy to the peanut gallery!

This addendum is how I'd have written the manual had I known then what I know now!

- John Beech, GM (and janitor), December 2005

**Check for most recent update at:
www.audacitymodels.com**

10.8 ADDENDUM

11.0 MAIN GEAR & FRAMES

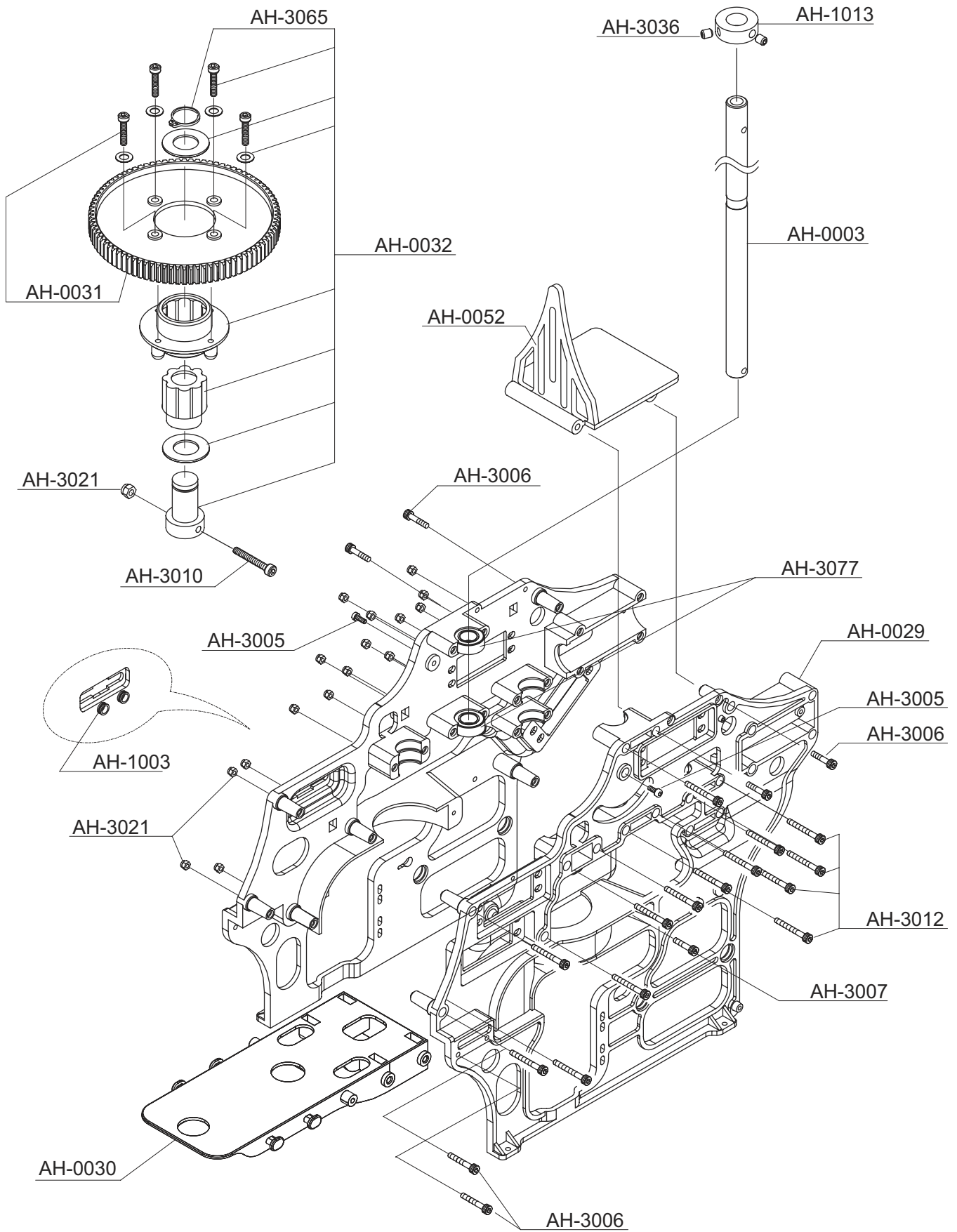

11.0 PARTS LIST

All screws, washers, nuts, and bearings on 11.7 Hardware List

PART #	DESCRIPTION	QTY	REMARKS
AH-0003	MAIN MAST		
	MAIN MAST	1	
AH-0029	MAIN FRAME		
	MAIN FRAME (R & L)	2	
AH-0030	RADIO PLATFORM ASSEMBLY		
	RADIO PLATFORM	1	
	M3x10 SOCKET HEAD BOLT	4	
AH-0031	MAIN GEAR ASSEMBLY		
	MAIN GEAR 89T	1	
	M3x10 SOCKET HEAD BOLT	4	
	M3 FLAT WASHER	4	
AH-0032	AUTO ROTATION ASSEMBLY		
	M11 SNAP RING	1	
	1 WAY BEARING HOUSING	1	
	1 WAY BEARING (1WC1216)	1	
	AUTO-ROTATION SPACER	2	
	1 WAY BEARING SHAFT	1	
AH-0052	GYROSCOPE PLATFORM ASSEMBLY		
	GYROSCOPE PLATFORM	1	
	M3x10 SOCKET HEAD BOLT	4	
AH-1003	SWITCH RUBBER		
	ROUND RUBBER GROMMET	2	
AH-1013	MAST STOPPER ASSEMBLY		
	MAST STOPPER	1	
	M4x4 SET SCREW	3	

11.1 ENGINE & BELT DRIVE

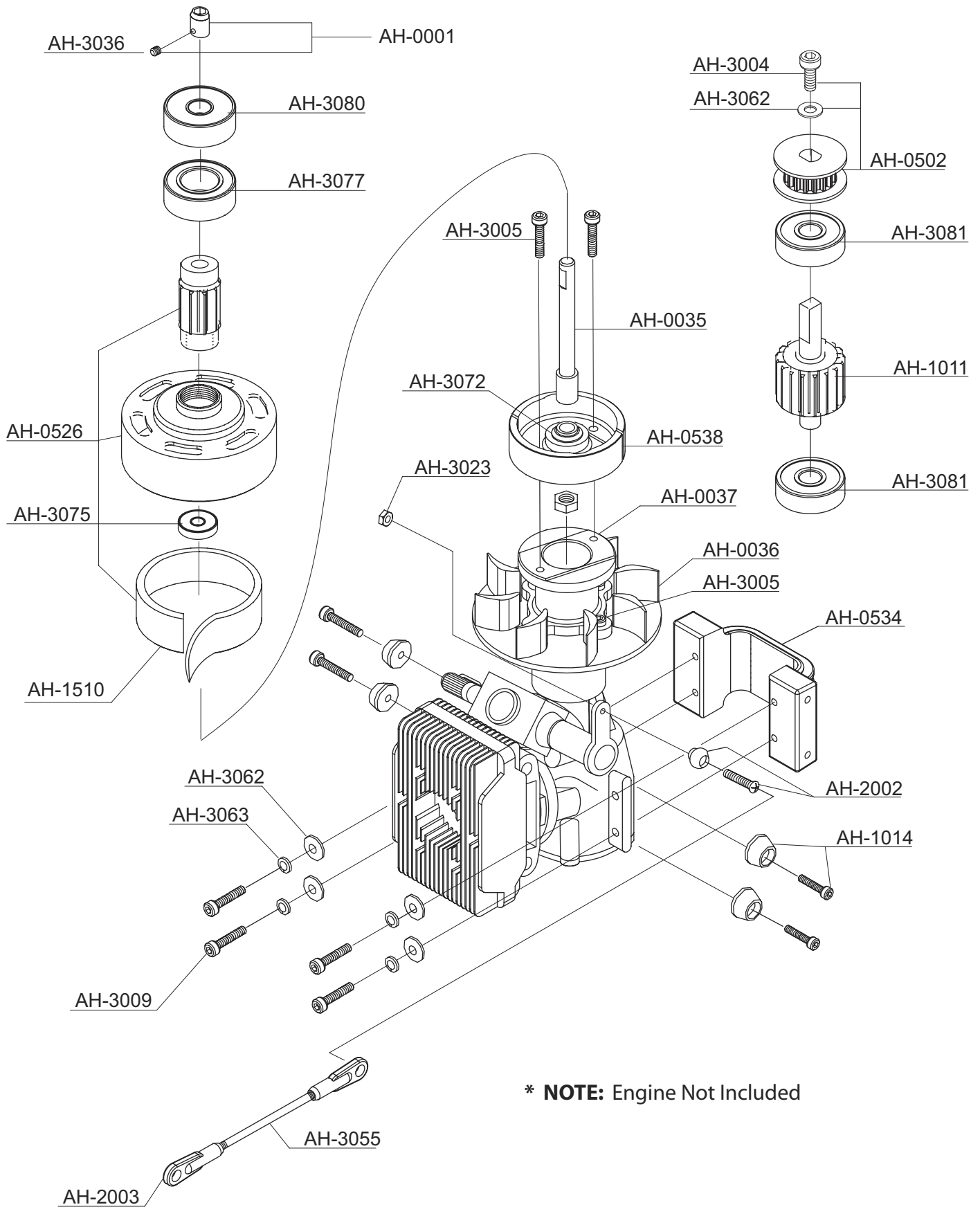

11.1 PARTS LIST

All screws, washers, nuts, and bearings on 11.7 Hardware List

<i>PART #</i>	<i>DESCRIPTION</i>	<i>QTY</i>	<i>REMARKS</i>
AH-0001	HEX START ADAPTER ASSEMBLY		
	HEX START ADAPTER	1	
	M4x04 SET SCREW	1	
AH-0035	START SHAFT		
	START SHAFT	1	
AH-0036	COOLING FAN		
	COOLING FAN	1	
AH-0037	CLUTCH HUB		
	CLUTCH HUB	1	
AH-0502	FRONT TAIL BELT PULLEY ASSEMBLY		
	FRONT TAIL BELT PULLEY	1	
	M3x06 SOCKET HEAD BOLT	1	
	M3 FLAT WASHER	1	
AH-0526	CLUTCH BELL ASSEMBLY		
	CLUTCH BELL	1	
	10T PINION GEAR 1:89 RATIO	1	
AH-0534	ENGINE MOUNT		
	ENGINE MOUNT 50	1	
AH-0538	CLUTCH ASSEMBLY		
	CLUTCH SHOE	1	
	M3x08 SOCKET HEAD BOLT	2	
AH-1011	TAIL DRIVE PINION GEAR		
	TAIL DRIVE PINION GEAR	1	
AH-1014	CAP BOLT HOLDER ASSEMBLY		
	CAP BOLT HOLDER	4	
	M3x12 SOCKET HEAD BOLT	4	
AH-1510	CLUTCH LINING		
	CLUTCH LINING	1	

11.2 CCPM, SWASHPLATE, & MIXER

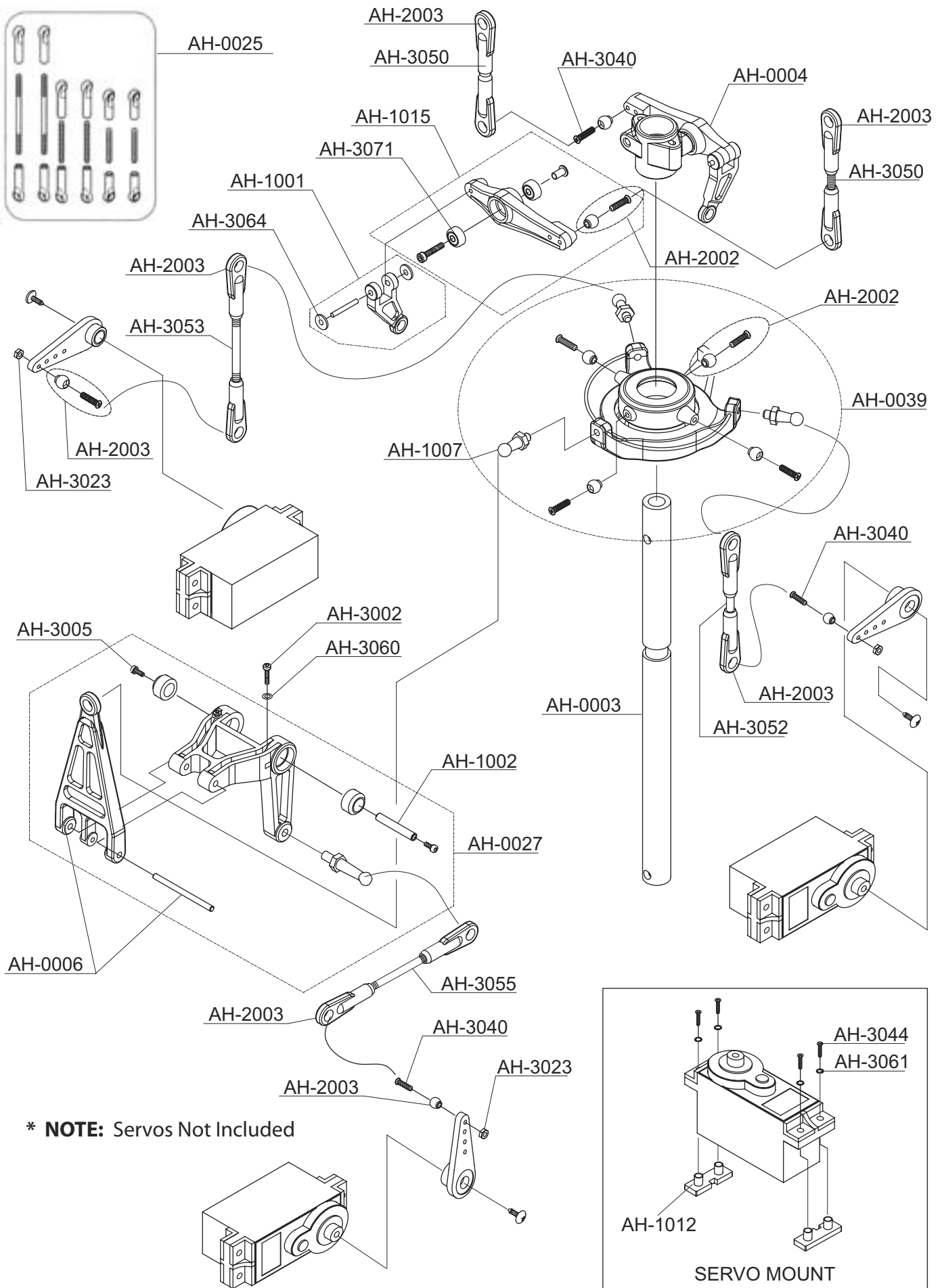

11.2 PARTS LIST

All screws, washers, nuts, and bearings on 11.7 Hardware List

PART #	DESCRIPTION	QTY	REMARKS
AH-0003	MAIN MAST		
	MAIN MAST	1	
AH-0004	WASHOUT ASSEMBLY		
	WASHOUT BASE	1	
AH-0006	SWASHPLATE ARM LINK ASSEMBLY		
	SWASHPLATE ARM LINK	1	
	ELEVATOR ARM PIN	1	
AH-0025	LINKAGE SET		
	M2.3x CONTROL ROD	2	
	M2.3x CONTROL ROD	2	
	M2.3x CONTROL ROD	2	
	-L- BALL LINK	8	
	-S- BALL LINK	4	
AH-0027	ELEVATOR ARM ASSEMBLY		
	SWASHPLATE ARM	1	
	ELEVATOR ARM	1	
	BALL ARM (14.5mm)	1	
	M2 FLAT WASHER	2	
	M2X10 SOCKET HEAD BOLT	2	
	ELEVATOR ARM PIN	1	
	ELEVATOR ARM BUSHING	2	
	M2 NUT	2	
	M3x8 SOCKET HEAD BOLT	2	
AH-0039	120° SWASHPLATE ASSEMBLY		
	SWASHPLATE	1	
	BALL ARM	3	
	JOINT BALL	4	
	M2x10 TAPPING SCREW	2	
	M2x13 TAPPING SCREW	2	
AH-1001	WASHOUT LINK ASSEMBLY		
	WASHOUT LINK	2	
	PIN 2 X 14	2	
	PERMANENT PUSH NUT	4	
AH-1002	ARM SHAFT		
	ARM SHAFT	1	
AH-1007	BALL ARM		
	BALL ARM	1	
AH-1012	SERVO MOUNT BOSS SET		
	SERVO BOSS PLATE	10	
AH-1015	WASHOUT ARM SET		
	WASHOUT ARM	2	
	WASHOUT ARM SHAFT	2	
	BEARING	4	
	M3x15 SOCKET HEAD BOLT	2	
	M2x10 FLAT HEAD BOLT	2	
	JOINT BALL	2	

11.3 MAIN ROTOR HEAD & SEESAW

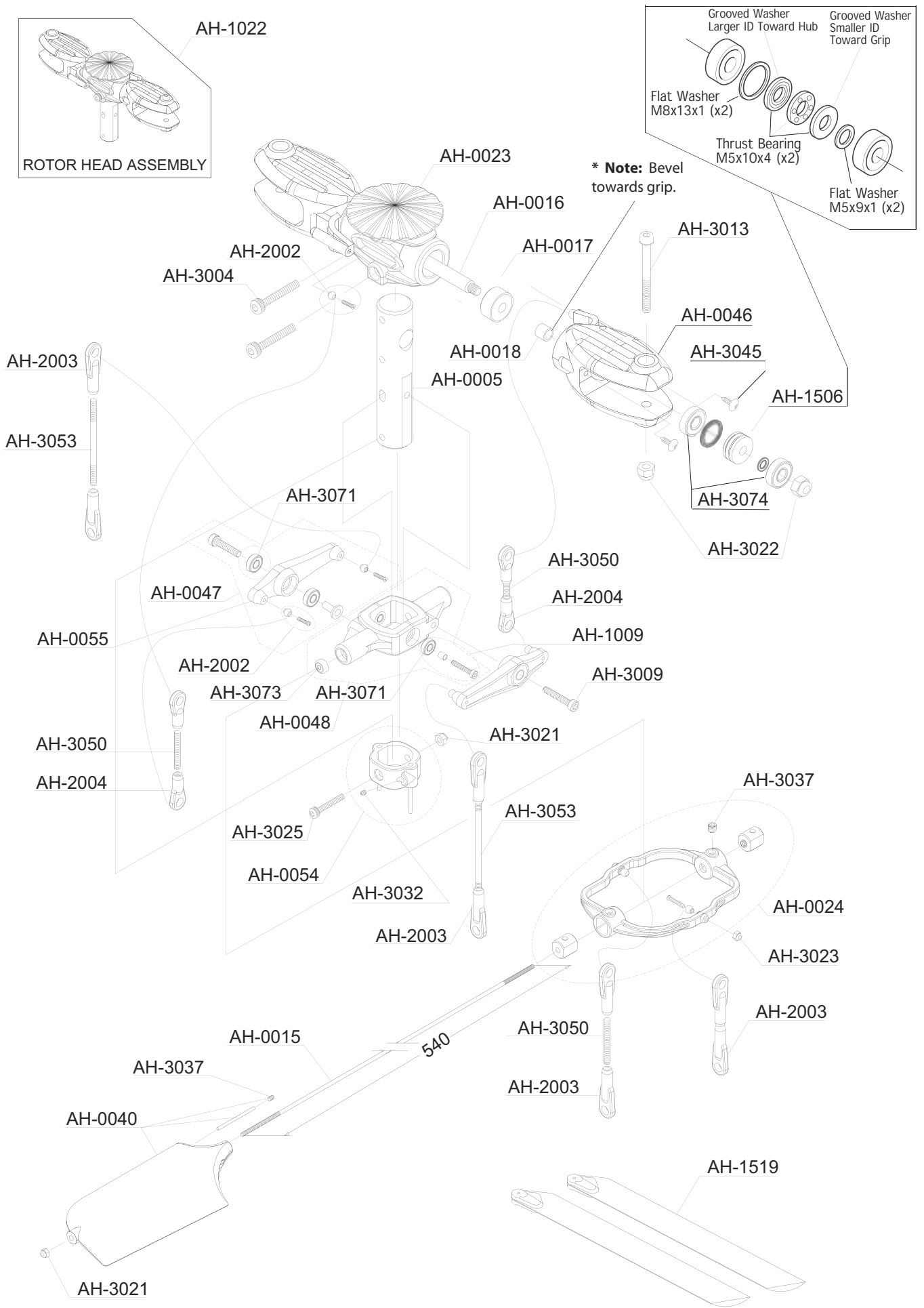

11.3 PARTS LIST

All screws, washers, nuts, and bearings on 11.7 Hardware List

PART #	DESCRIPTION	QTY	REMARKS
AH-0005	CENTER HUB ASSEMBLY		
	CENTER HUB	1	
	M3x06 SOCKET HEAD BOLT	4	
AH-0015	FLYBAR		
	FLYBAR	2	
AH-0016	SPINDLE SHAFT ASSEMBLY		
	SPINDLE SHAFT	1	
	NYLON LOCK NUT	1	
AH-0017	DAMPER RUBBER		
	DAMPER RUBBER	4	
AH-0018	GRIP SPACER		
	GRIP SPACER	2	
AH-0023	ONE PIECE MAIN ROTOR HUB		
	ONE PIECE MAIN ROTOR HUB	1	
AH-0024	CONTROL LEVER ASSEMBLY		
	ARM	1	
	FLY BAR STOPPER	2	
	STAINLESS STEEL BALL	2	
	M4x6 SET SCREW	2	
	M2x10 PHILLIPS HEAD SCREW	2	
	M2HEX NUT	2	
AH-0040	FLYBAR PADDLE ASSEMBLY		
	FLYBAR PADDLE	2	
	M3 NYLON LOCK NUT	2	
	M4X06 SET SCREW	2	
	3X70 WEIGHT	2	
AH-0046	MAIN ROTOR GRIP ASSEMBLY		
	MAIN ROTOR GRIP	2	
	JOINT BALL	2	
	M2x8 FLAT HEAD BOLT	2	
AH-0047	SEESAW ARM ASSEMBLY		
	SEESAW ARM	2	
	M3 X 15 SOCKET HEAD BOLT	2	
	BEARING (L840ZZ)	4	
	SPACER	2	
	BALL JOINT	4	
	M2x10 PHILLIPS HEAD SCREW	4	
AH-0048	SEESAW CENTER ASSEMBLY		
	SEESAW CENTER	1	
	M3x8 SEESAW CENTER BOLT	2	
	BEARING (L630ZZ)	2	
	BEARING (L840ZZ)	2	
SPACER	2		
AH-0054	ROTOR HUB ADAPTER ASSEMBLY		
	ROTOR HUB ADAPTER GUIDE PIN	2	
	M3x22 SOCKET HEAD BOLT	1	
	M3 NYLON LOCK NUT	1	
	M3s5 SET SCREW	2	
AH-0055	SEESAW ARMS		
	SEESAW ARM	2	
AH-1009	SEESAW SPACER ASSEMBLY		
	SEESAW SPACER	2	
	BEARING (L840ZZ)	2	
	M3x8 SEESAW CENTER BOLT	2	
AH-1022	ROTOR HEAD ASSEMBLY		
	ROTOR HEAD ASSEMBLY	1	
AH-1506	ROTOR GRIP BEARING & SPACER		
	T5-10 BEARING	2	
	5x9x1 WASHER	2	
AH-1519	8x13x1 WASHER	2	
	MAIN ROTOR BLADE		
	04x600 MAIN ROTOR BLADE	1 PAIR	

11.4 SUPPORTS, GUIDES, & H-FIN

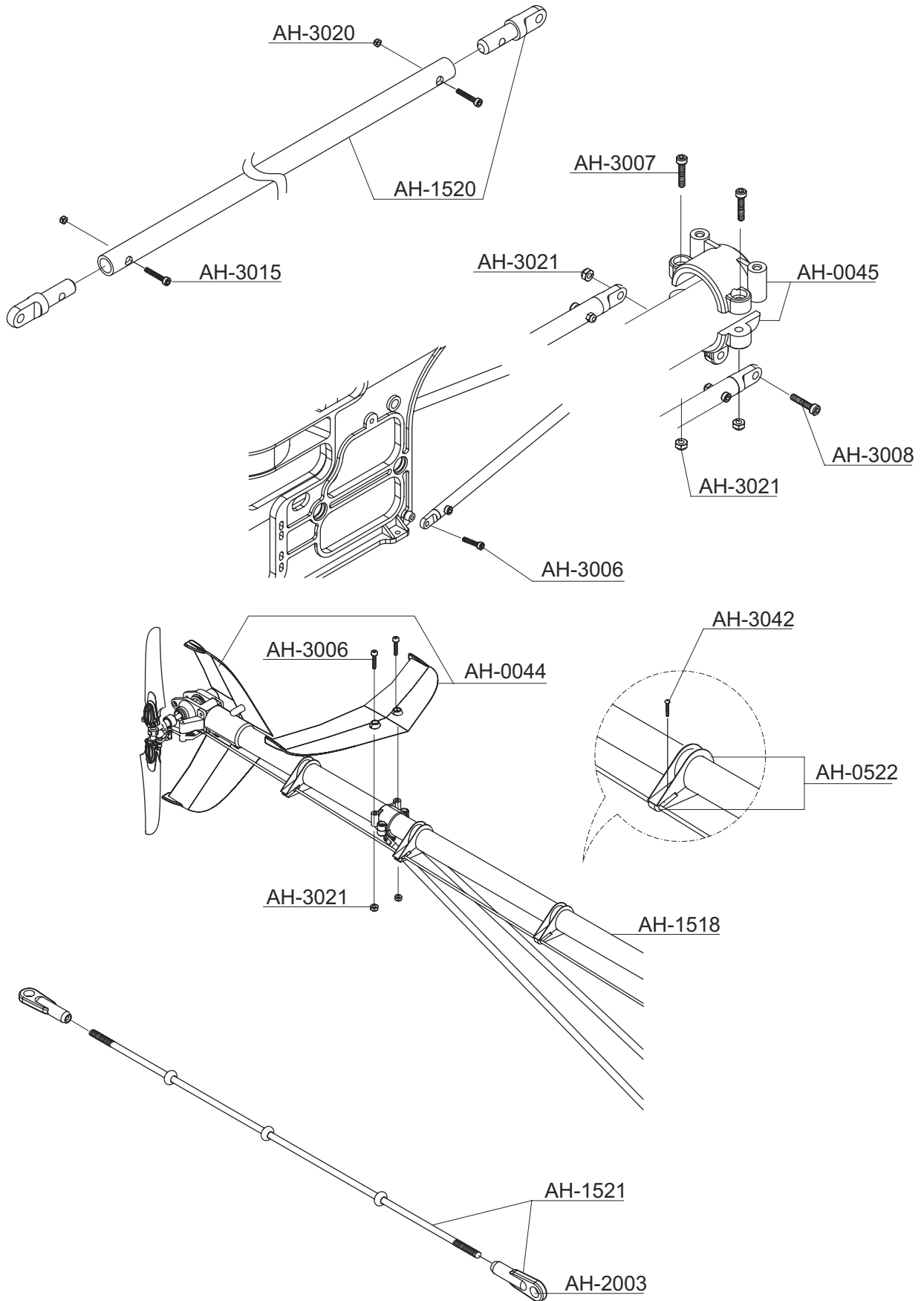

11.4 PARTS LIST

All screws, washers, nuts, and bearings on 11.7 Hardware List

PART #	DESCRIPTION	QTY	REMARKS
AH-0044	TAIL FIN SET		
	HORIZONTAL FIN	1	
	VERTICAL FIN	1	
	M3x10 SOCKET HEAD BOLT	4	
	M3 NYLON LOCK NUT	2	
AH-0045	TAIL SUPPORT CLAMP SET		
	TAIL SUPPORT CLAMP, UPPER	1	
	TAIL SUPPORT CLAMP, LOWER	1	
	M3x12 SOCKET HEAD BOLT	2	
	M3x22 SOCKET HEAD BOLT	1	
	M3 NYLON LOCK NUT	3	
	M3 FLAT WASHER	2	
	AH-0522	TAIL ROD GUIDE ASSEMBLY	
PUSH ROD GUIDE		4	
M2x8 TAPPING SCREW		4	
AH-1518	TAIL BOOM		
	TAIL BOOM (04x690)	1	
AH-1520	BOOM SUPPORT ASSEMBLY		
	ALUMINUM BOOM SUPPORT	2	
	BOOM SUPPORT END	4	
	M2.6x10 SOCKET HEAD BOLT	4	
	M2.6 NYLON LOCK NUT	4	
	M3x10 SOCKET HEAD BOLT	2	
AH-1521	TAIL ROTOR PUSHROD ASSEMBLY		
	TAIL ROTOR PUSHROD	2	
	TAIL ROTOR PUSHROD BUSHING	4	
	BALL LINK END	2	

11.5 TAIL ROTOR, BELT, & V-FIN

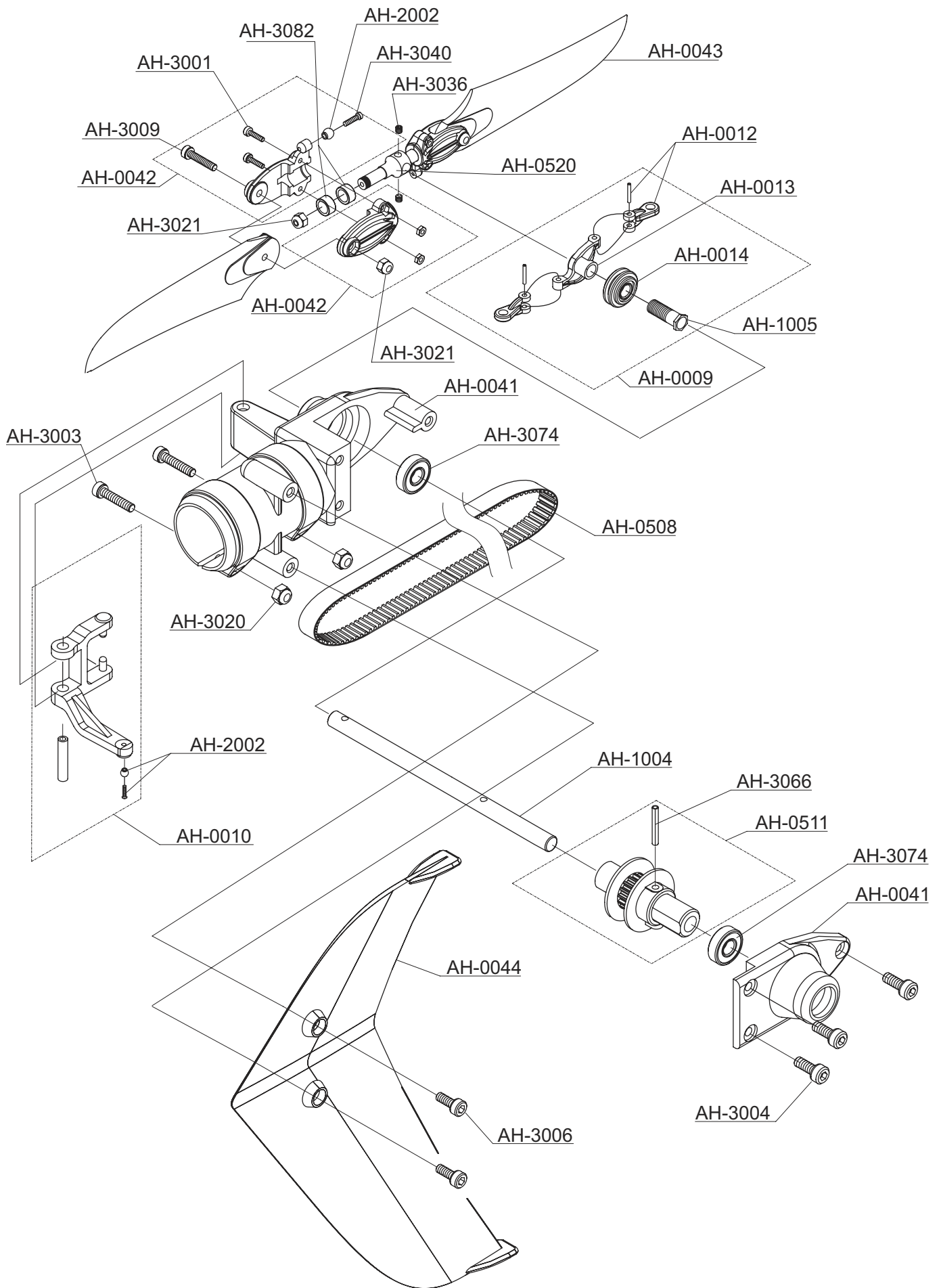

11.5 PARTS LIST

All screws, washers, nuts, and bearings on 11.7 Hardware List

PART #	DESCRIPTION	QTY	REMARKS
AH-0009	TAIL SLIDE RING ASSEMBLY		
	TAIL PITCH PLATE	1	
	TAIL PITCH LINK	2	
	TAIL PITCH LINK PIN	2	
	TAIL SLIDE RING	1	
	SLIDE RING BEARING	1	
AH-0010	TAIL PITCH CONTROL LEVER ASSEMBLY		
	TAIL PITCH CONTROL LEVER	1	
	TAIL LEVER BUSHING	1	
	M2x8 PHILLIPS HEAD SCREW	1	
	STAINLESS STEEL BALL	1	
AH-0012	TAIL PITCH LINK ASSEMBLY		
	TAIL PITCH LINK	2	
	TAIL PITCH LINK PIN	2	
AH-0013	TAIL PITCH PLATE		
	TAIL PITCH PLATE	1	
AH-0014	TAIL SLIDE RING		
	TAIL SILDE RING	1	
	TAIL SLIDE RING BEARING (L1170ZZ)	1	
AH-0041	TAIL GEAR CASE ASSEMBLY		
	TAIL GEAR CASE, R	1	
	TAIL GEAR CASE, L	1	
	M2.6x12 SOCKET HEAD BOLT	2	
	M2.6 NUT	2	
	M3x6 SOCKET HEAD BOLT	3	
AH-0042	TAIL ROTOR GRIP		
	TAIL ROTOR GRIP, R	2	
	TAIL ROTOR GRIP, L	2	
	STAINLESS STEEL BALL	2	
	M2x8 PHILLIPS HEAD SCREW	2	
	M2x8 SOCKET HEAD BOLT	4	
	M2 HEX NUT	4	
	M3x15 SOCKET HEAD BOLT	2	
	M3 NYLON LOCK NUT	2	
	AH-0043	TAIL ROTOR BLADES	
TAIL ROTOR BLADE		2	
AH-0044	TAIL FIN SET		
	HORIZONTAL FIN	1	
	VERTICAL FIN	1	
	M3x10 SOCKET HEAD BOLT	4	
	M3 NYLON LOCK NUT	2	
AH-0508	TAIL DRIVE BELT		
	TAIL DRIVE BELT S3M - 1596	1	
AH-0511	TAIL PULLEY ASSEMBLY		
	TAIL PULLEY	1	
	SPRING PIN, 2x14	1	
AH-0520	TAIL ROTOR CENTER HUB ASSEMBLY		
	TAIL ROTOR CENTER HUB	1	
	M4x4 SET SCREW	2	
	M3 NYLON LOCK NUT	2	
AH-1004	TAIL OUTPUT SHAFT		
	TAIL OUTPUT SHAFT	1	
AH-1005	TAIL SLIDE RING SLEEVE		
	TAIL SLIDE RING SLEEVE	1	

11.6 SKIDS, CANOPY, & FUEL TANK

MANUAL

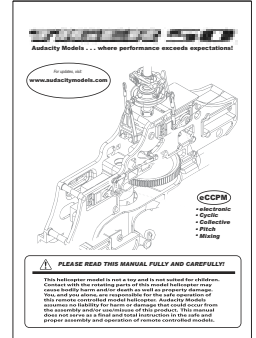

AH-0550

DECAL SHEET

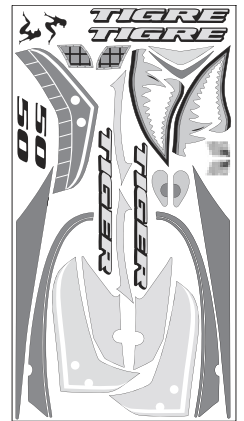

AH-0549

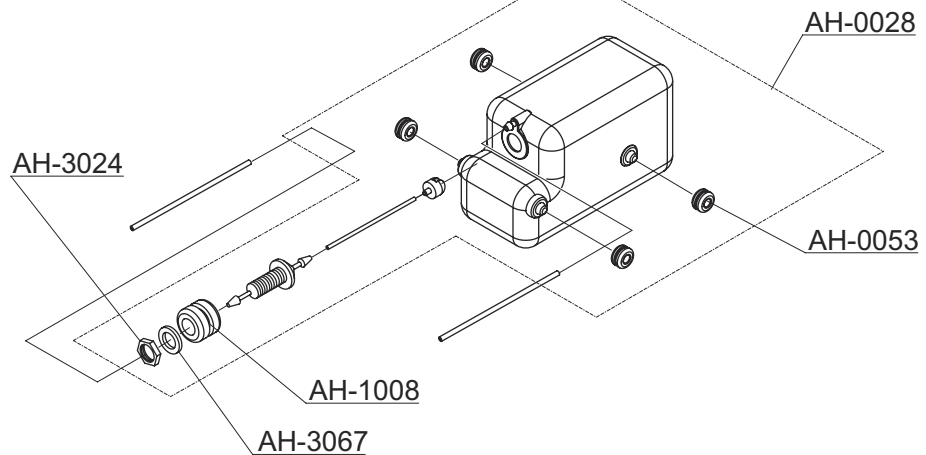
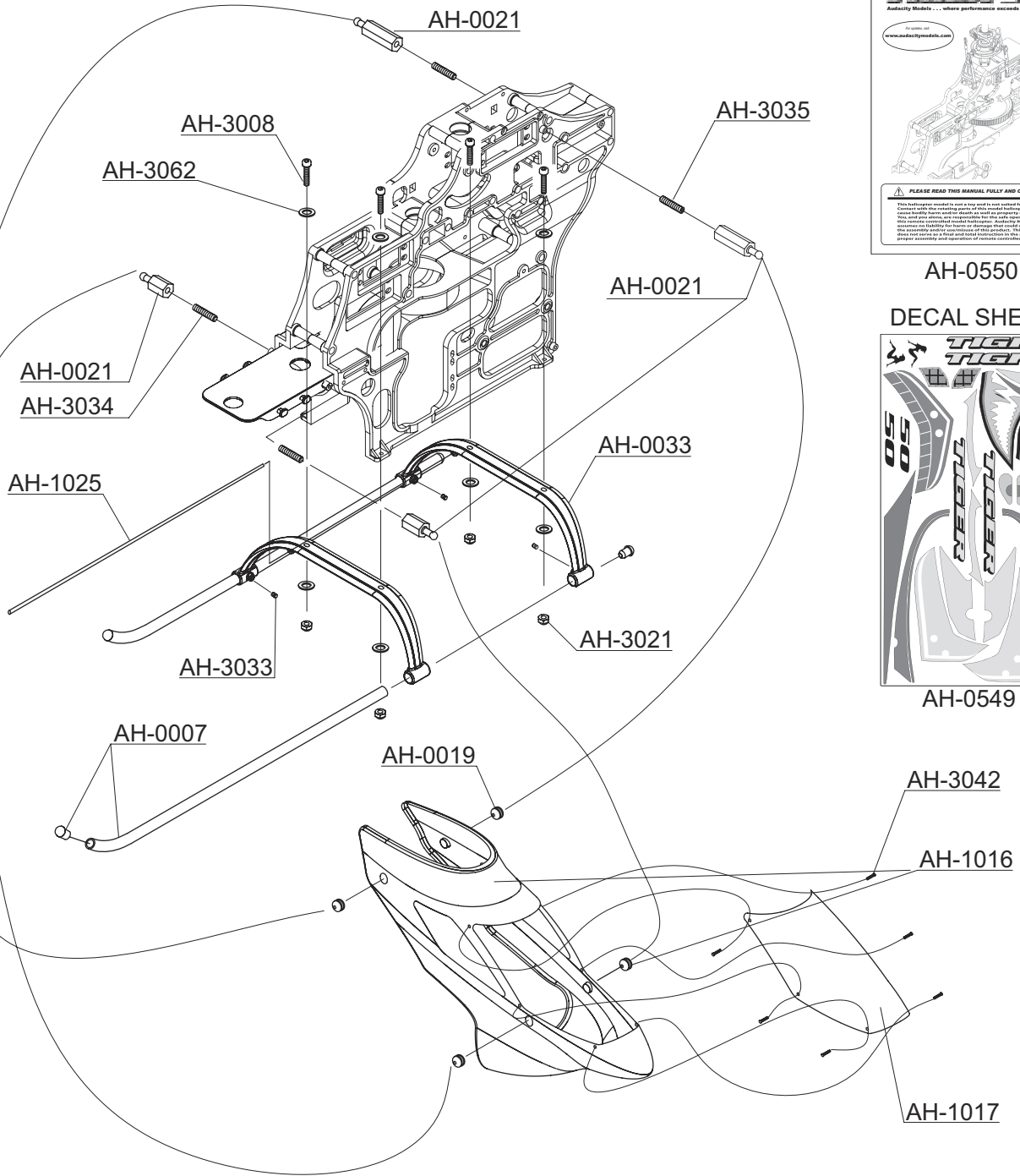

11.6 PARTS LIST

All screws, washers, nuts, and bearings on 11.7 Hardware List

PART #	DESCRIPTION	QTY	REMARKS
AH-0007	LANDING SKID ASSEMBLY		
	LANDING SKID	2	
	SKID CAP	4	
AH-0019	RUBBER GROMMET SET		
	RUBBER GROMMET	4	
AH-0021	CABIN MOUNT STANDOFF SET		
	FRONT STANDOFF (10mm x 1)	2	
	REAR STANDOFF (20mm x 1)	2	
AH-0028	FUEL TANK ASSEMBLY		
	FUEL TANK (14 oz)	1	
	FUEL TANK CLUNK PICKUP	1	
	FEED NIPPLE	1	
	RUBBER TANK GROMMET	1	
	SILICONE FUEL TUBE	1	
	M7 FLAT WASHER (7x12x1)	1	
	M7 NUT	2	
	RUBBER MOUNTING GROMMET	4	
AH-0033	LANDING GEAR STRUT ASSEMBLY		
	LANDING GEAR STRUT	2	
	M3x6 SET SCREW	4	
AH-0053	RUBBER MOUNTING GROMMET SET		
	RUBBER MOUNTING GROMMET	4	
AH-0549	STICKER		
	STICKER	1	
AH-0550	MANUAL		
	MANUAL	1	
AH-1008	FUEL TANK RUBBER GROMMET		
	FUEL TANK RUBBER GROMMET	2	
AH-1016	BODY SET		
	BODY	1	
	CANOPY	1	
	M2x8 TAPPING SCREW	6	
	RUBBER GROMMET	4	
AH-1017	CANOPY ASSEMBLY		
	CANOPY	1	
	M2x8 TAPPING SCREW	6	
AH-1025	ANTENNA GUIDE TUBE		
	ANTENNA GUIDE TUBE	1	

11.7 HARDWARE LIST

BALL LINK & ENDS

PART #	DESCRIPTION	QTY
AH-2001	STAINLESS STEEL BALL JOINT SET	
	STAINLESS STEEL BALL JOINT	1
	M2x8 PHILLIPS HEAD SCREW	1
AH-2002	STAINLESS STEEL BALL JOINT SET	
	STAINLESS STEEL BALL JOINT	1
	M2x10 PHILLIPS HEAD SCREW	1
AH-2003	HD BALL LINK END, LONG	1
AH-2004		1

SOCKET HEAD BOLTS

PART #	DESCRIPTION	QTY
AH-3001	M2x8 SOCKET HEAD BOLT	1
AH-3002	M2x10 SOCKET HEAD BOLT	1
AH-3003	M2.6x12 SOCKET HEAD BOLT	1
AH-3004	M3x6 SOCKET HEAD BOLT	1
AH-3005	M3x8 SOCKET HEAD BOLT	1
AH-3006	M3x10 SOCKET HEAD BOLT	1
AH-3007	M3x12 SOCKET HEAD BOLT	1
AH-3008	M3x14 SOCKET HEAD BOLT	1
AH-3009	M3x15 SOCKET HEAD BOLT	1
AH-3010	M3x22 SOCKET HEAD SHOULDER BOLT	1
AH-3011	M3x30 SOCKET HEAD BOLT	1
AH-3012	M3x38 SOCKET HEAD BOLT	1
AH-3013	M4x30 SOCKET HEAD SHOULDER BOLT	1
AH-3014	M3x35 SOCKET HEAD BOLT	1
AH-3015	M2.6x10 SOCKET HEAD BOLT	1
AH-3025	M3x3 SOCKET HEAD BOLT	1

NYLON LOCK NUTS

PART #	DESCRIPTION	QTY
AH-3020	M2.6 NYLON LOCK NUT	1
AH-3021	M3 NYLON LOCK NUT	1
AH-3022	M4 NYLON LOCK NUT	1

HEX NUTS

PART #	DESCRIPTION	QTY
AH-3023	M2 HEX NUT	1
AH-3024	M7 HEX NUT	1

SET SCREWS

PART #	DESCRIPTION	QTY
AH-3030	M3x3 SET SCREW	1
AH-3031	M3x4 SET SCREW	1
AH-3032	M3x5 SET SCREW	1
AH-3033	M3x6 SET SCREW	1
AH-3034	M3x12 SET SCREW	1
AH-3035	M3x15 SET SCREW	1
AH-3036	M4x4 SET SCREW	1
AH-3037	M4x6 SET SCREW	1

PHILLIPS HEAD SCREWS

PART #	DESCRIPTION	QTY
AH-3040	M2x8 PHILLIPS HEAD SCREW	1
AH-3041	M2x10 PHILLIPS HEAD SCREW	1

SELF TAPPING SCREWS

PART #	DESCRIPTION	QTY
AH-3042	M2x8 SELF TAPPING SCREW	1
AH-3044	M2.6x12 SELF TAPPING SCREW	1
AH-3045	M3x6 SELF TAPPING SCREW	1

THREADED ROD

PART #	DESCRIPTION	QTY
AH-3050	M2.3x12 THREADED ROD	1
AH-3051	M2.3x20 THREADED ROD	1
AH-3052	M2.3x30 THREADED ROD	1
AH-3053	M2.3x40 THREADED ROD	1
AH-3055	M2.3x50 THREADED ROD	1

FLAT WASHERS

PART #	DESCRIPTION	QTY
AH-3060	M2 FLAT WASHER	1
AH-3061	M2.6 FLAT WASHER	1
AH-3062	M3 FLAT WASHER	1

LOCK WASHERS

PART #	DESCRIPTION	QTY
AH-3063	M3 LOCK WASHER	1

PERMANENT PUSH NUTS

PART #	DESCRIPTION	QTY
AH-3064	M2 PERMANENT PUSH NUT	1

SNAP RINGS

PART #	DESCRIPTION	QTY
AH-3065	M11 SNAP RING	1

SPRING PINS

PART #	DESCRIPTION	QTY
AH-3066		1

FLAT WASHERS

PART #	DESCRIPTION	QTY
AH-3067	7x12x1 FLAT WASHER	1

BEARINGS

PART #	DESCRIPTION	QTY
AH-3071	L840ZZ 4x8x3	1
AH-3072	HF0612 Oneway 6x10x12	1
AH-3073	L630ZZ 3x6x2.5	1
AH-3074	L1350ZZ 5x13x4	1
AH-3075	L1050ZZ 5x10x4	1
AH-3077	L1910ZZ 10x19x7	1
AH-3080	R1950ZZ 5X19X6	1
AH-3081	R1960ZZ 6x19x6	1
AH-3082	R840ZZ 3x7x3	1

12.0 ACCESSORIES

Ultra high quality accessories, which won't break the bank, crafted by our crew. **PROMODELER . . . when it's more than a hobby!**[™]

www.promodeler.com



PRO-0063 - Training Gear



PRO-0004 - Filter Filter T



PRO-0062 - Exhaust Deflector 35°



PRO-0057P - 3D Paddles (pink)
PRO-0057W (white), PRO-0059 (yellow)



PRO-0061 - 3D Hopper Tank (3oz)



PRO-0003 - Shutoff & Plug (2-yellow)



PRO-0065 - Limited Slip Drive



PRO-0009P - Skid Guard (pink)
PRO-0009W (white), PRO-0009Y (yellow)



PRO-0056 - Fuel Filters (2-clear)



PRO-0065 - PRO mini-pump
(compatible w/glo-fuel and gasoline)



PRO-0053 - PRO Muffler 50



PRO-0016 - Hopper Tank (2oz)

www.promodeler.com

12.1 ACCESSORIES

Ultra high quality accessories, which won't break the bank, crafted by the crew at **PROMODELER . . . when it's more than a hobby!**[™]



Designed to store your transmitter, starter and battery, a gallon of fuel, plus the usual accoutrements like spare plugs, tools, field charger, battery tester and more, the superb **PROMODELER Flight Box** is perfect for the experienced pro. Molded in bright Cub yellow to reflect the sun, the strong and durable PVC design assembles in minutes using a screwdriver - no painting! With a nifty storage top that lifts and pivots into place transforming into a conveniently angled transmitter stand, your tranny is both positioned for ready access and off the ground. Unlike old-fashioned painted wood, clean up is easy too as the fuel proof **Flight Box** shines with just soap and water. Combining high-tech design and low-tech practicality, for what's really needed at the field, the pros pack a **PROMODELER Flight Box**.



PRO-0050 - *Flight Box* (yellow)

www.promodeler.com



12.2 ACCESSORIES

www.modelsport.com

At last, an easy way to learn to fly R/C helicopters! From the producers of modelSPORT video-magazine comes R/C Basics: Hover - Flight Training!

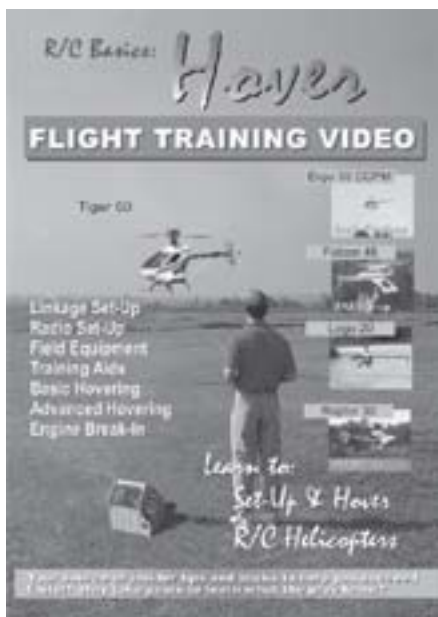

Better than show-and-tell because you can play it over and over. Watch both how a properly set-up helicopter performs, and hear what it should sound like! Learn the insider's tips and tricks as different mechanical set-ups are performed. From what a beginner needs, through an expert's 3D set-up, this program features several different helicopters. Models range from sport and aerobatic helicopters through electric and even scale. Two leading radio-brands are demonstrated (Futaba and JR) to include conventional and CCPM set-ups! There are even tips for setting up helicopter engines, preventive maintenance, tools, flight simulators and more! But that's not all as you're guided through a flight training process that starts with skidding an inch off the ground and culminates in your learning the nose-in hover. Because helicopter flight starts and ends in a hover, this 2-hour long program is perfect for gaining the confidence to set your model up correctly and learn to hover it ... you can succeed!

RCB002 - *R/C Basics: Hover - Flight Training*

Surf to www.modelsport.com to get your own personal copy!

Learn to tune and adjust model engines like a pro! From the producers of modelSPORT video-magazine comes R/C Basics: aboutENGINES



R/C model engines can be both frustrating and confusing, but with the help of this nearly 3-hour long program, you'll soon be tuning engines like a pro - it's loaded with tips! From a standard .46-class ABC engine to sophisticated multi-cylinder 4-strokes and gas burners, you'll soon be up to speed. Learn about fuel systems, equipment and tools, safety, and even about gasoline vs. alcohol fuels. You'll learn about Walbro pump-carburetors, how to adjust valves, tips and tricks for fine tuning 2-needle carbs, heat ranges of glo plugs, and even arcane secrets like how to read spark plug color! You'll also learn about engine handling techniques, engine assembly tricks, and more! ABC-class engines break in differently from ringed helicopter engines - and you'll know why and how to do it properly. Why take years to learn what the pros know?

RCB003 - *R/C Basics: aboutENGINES*

www.modelsport.com

TIGER 50

Audacity Models . . . where performance exceeds expectations!



A paper document like this manual freezes in time the technical knowledge, how-to tips, programming ideas, and everything else we subsequently learn about the Tiger 50. We encourage you to visit our website for updates, as well as other bits of information we may discover and share.

www.audacitymodels.com